

Software Manual



TD-SCDMA Base Station Test

Applications Firmware R&S® FS-K76

1300.7291.02



This Software Manual describes the following models:

- R&S®FMU
- R&S®FSG
- R&S®FSMR
- R&S®FSP
- R&S®FSQ
- R&S®FSU
- R&S®FSUP

Dear Customer,

throughout this manual, FS–K76 is generally used as an abbreviation for the software option R&S FS–K76. The Spectrum Analyzers R&S FSU and R&S FSP are abbreviated as FSU and FSP.
CDMA2000® is a registered trademark of the Telecommunications Industry Association (TIA –USA).

Basic Safety Instructions

Always read through and comply with the following safety instructions!









All plants and locations of the Rohde & Schwarz group of companies make every effort to keep the safety standards of our products up to date and to offer our customers the highest possible degree of safety. Our products and the auxiliary equipment they require are designed, built and tested in accordance with the safety standards that apply in each case. Compliance with these standards is continuously monitored by our quality assurance system. The product described here has been designed, built and tested in accordance with the attached EC Certificate of Conformity and has left the manufacturer's plant in a condition fully complying with safety standards. To maintain this condition and to ensure safe operation, you must observe all instructions and warnings provided in this manual. If you have any questions regarding these safety instructions, the Rohde & Schwarz group of companies will be happy to answer them.







Furthermore, it is your responsibility to use the product in an appropriate manner. This product is designed for use solely in industrial and laboratory environments or, if expressly permitted, also in the field and must not be used in any way that may cause personal injury or property damage. You are responsible if the product is used for any intention other than its designated purpose or in disregard of the manufacturer's instructions. The manufacturer shall assume no responsibility for such use of the product.

The product is used for its designated purpose if it is used in accordance with its product documentation and within its performance limits (see data sheet, documentation, the following safety instructions). Using the product requires technical skills and a basic knowledge of English. It is therefore essential that only skilled and specialized staff or thoroughly trained personnel with the required skills be allowed to use the product. If personal safety gear is required for using Rohde & Schwarz products, this will be indicated at the appropriate place in the product documentation. Keep the basic safety instructions and the product documentation in a safe place and pass them on to the subsequent users.

Observing the safety instructions will help prevent personal injury or damage of any kind caused by dangerous situations. Therefore, carefully read through and adhere to the following safety instructions before and when using the product. It is also absolutely essential to observe the additional safety instructions on personal safety, for example, that appear in relevant parts of the product documentation. In these safety instructions, the word "product" refers to all merchandise sold and distributed by the Rohde & Schwarz group of companies, including instruments, systems and all accessories.

Symbols and safety labels

							
Notice, general danger location Observe product documentation	Caution when handling heavy equipment	Danger of electric shock	Warning! Hot surface	PE terminal	Ground	Ground terminal	Be careful when handling electrostatic sensitive devices

					
ON/OFF supply voltage	Standby indication	Direct current (DC)	Alternating current (AC)	Direct/alternating current (DC/AC)	Device fully protected by double (reinforced) insulation

Tags and their meaning

The following signal words are used in the product documentation in order to warn the reader about risks and dangers.



indicates a hazardous situation which, if not avoided, will result in death or serious injury.



indicates a hazardous situation which, if not avoided, could result in death or serious injury.



indicates a hazardous situation which, if not avoided, could result in minor or moderate injury.



indicates the possibility of incorrect operation which can result in damage to the product.

In the product documentation, the word ATTENTION is used synonymously.

These tags are in accordance with the standard definition for civil applications in the European Economic Area. Definitions that deviate from the standard definition may also exist in other economic areas or military applications. It is therefore essential to make sure that the tags described here are always used only in connection with the related product documentation and the related product. The use of tags in connection with unrelated products or documentation can result in misinterpretation and in personal injury or material damage.

Operating states and operating positions

The product may be operated only under the operating conditions and in the positions specified by the manufacturer, without the product's ventilation being obstructed. If the manufacturer's specifications are not observed, this can result in electric shock, fire and/or serious personal injury or death. Applicable local or national safety regulations and rules for the prevention of accidents must be observed in all work performed.

1. Unless otherwise specified, the following requirements apply to Rohde & Schwarz products: predefined operating position is always with the housing floor facing down, IP protection 2X, pollution severity 2, overvoltage category 2, use only indoors, max. operating altitude 2000 m above sea level, max. transport altitude 4500 m above sea level. A tolerance of $\pm 10\%$ shall apply to the nominal voltage and $\pm 5\%$ to the nominal frequency.
2. Do not place the product on surfaces, vehicles, cabinets or tables that for reasons of weight or stability are unsuitable for this purpose. Always follow the manufacturer's installation instructions when installing the product and fastening it to objects or structures (e.g. walls and shelves). An installation that is not carried out as described in the product documentation could result in personal injury or death.
3. Do not place the product on heat-generating devices such as radiators or fan heaters. The ambient temperature must not exceed the maximum temperature specified in the product documentation or in the data sheet. Product overheating can cause electric shock, fire and/or serious personal injury or death.

Electrical safety

If the information on electrical safety is not observed either at all to the extent necessary, electric shock, fire and/or serious personal injury or death may occur.

1. Prior to switching on the product, always ensure that the nominal voltage setting on the product matches the nominal voltage of the AC supply network. If a different voltage is to be set, the power fuse of the product may have to be changed accordingly.
2. In the case of products of safety class I with movable power cord and connector, operation is permitted only on sockets with an earthing contact and protective earth connection.
3. Intentionally breaking the protective earth connection either in the feed line or in the product itself is not permitted. Doing so can result in the danger of an electric shock from the product. If extension cords or connector strips are implemented, they must be checked on a regular basis to ensure that they are safe to use.
4. If the product does not have a power switch for disconnection from the AC supply network, the plug of the connecting cable is regarded as the disconnecting device. In such cases, always ensure that the power plug is easily reachable and accessible at all times (corresponding to the length of connecting cable, approx. 2 m). Functional or electronic switches are not suitable for providing disconnection from the AC supply network. If products without power switches are integrated into racks or systems, a disconnecting device must be provided at the system level.
5. Never use the product if the power cable is damaged. Check the power cable on a regular basis to ensure that it is in proper operating condition. By taking appropriate safety measures and carefully laying the power cable, you can ensure that the cable will not be damaged and that no one can be hurt by, for example, tripping over the cable or suffering an electric shock.
6. The product may be operated only from TN/TT supply networks fused with max. 16 A (higher fuse only after consulting with the Rohde & Schwarz group of companies).
7. Do not insert the plug into sockets that are dusty or dirty. Insert the plug firmly and all the way into the socket. Otherwise, sparks that result in fire and/or injuries may occur.
8. Do not overload any sockets, extension cords or connector strips; doing so can cause fire or electric shocks.
9. For measurements in circuits with voltages $V_{\text{rms}} > 30 \text{ V}$, suitable measures (e.g. appropriate measuring equipment, fusing, current limiting, electrical separation, insulation) should be taken to avoid any hazards.
10. Ensure that the connections with information technology equipment, e.g. PCs or other industrial computers, comply with the IEC60950-1/EN60950-1 or IEC61010-1/EN 61010-1 standards that apply in each case.
11. Unless expressly permitted, never remove the cover or any part of the housing while the product is in operation. Doing so will expose circuits and components and can lead to injuries, fire or damage to the product.
12. If a product is to be permanently installed, the connection between the PE terminal on site and the product's PE conductor must be made first before any other connection is made. The product may be installed and connected only by a licensed electrician.
13. For permanently installed equipment without built-in fuses, circuit breakers or similar protective devices, the supply circuit must be fused in such a way that anyone who has access to the product, as well as the product itself, is adequately protected from injury or damage.

14. Use suitable overvoltage protection to ensure that no overvoltage (such as that caused by a bolt of lightning) can reach the product. Otherwise, the person operating the product will be exposed to the danger of an electric shock.
15. Any object that is not designed to be placed in the openings of the housing must not be used for this purpose. Doing so can cause short circuits inside the product and/or electric shocks, fire or injuries.
16. Unless specified otherwise, products are not liquid-proof (see also section "Operating states and operating positions", item 1. Therefore, the equipment must be protected against penetration by liquids. If the necessary precautions are not taken, the user may suffer electric shock or the product itself may be damaged, which can also lead to personal injury.
17. Never use the product under conditions in which condensation has formed or can form in or on the product, e.g. if the product has been moved from a cold to a warm environment. Penetration by water increases the risk of electric shock.
18. Prior to cleaning the product, disconnect it completely from the power supply (e.g. AC supply network or battery). Use a soft, non-linting cloth to clean the product. Never use chemical cleaning agents such as alcohol, acetone or diluents for cellulose lacquers.

Operation

1. Operating the products requires special training and intense concentration. Make sure that persons who use the products are physically, mentally and emotionally fit enough to do so; otherwise, injuries or material damage may occur. It is the responsibility of the employer/operator to select suitable personnel for operating the products.
2. Before you move or transport the product, read and observe the section titled "Transport".
3. As with all industrially manufactured goods, the use of substances that induce an allergic reaction (allergens) such as nickel cannot be generally excluded. If you develop an allergic reaction (such as a skin rash, frequent sneezing, red eyes or respiratory difficulties) when using a Rohde & Schwarz product, consult a physician immediately to determine the cause and to prevent health problems or stress.
4. Before you start processing the product mechanically and/or thermally, or before you take it apart, be sure to read and pay special attention to the section titled "Waste disposal", item 1.
5. Depending on the function, certain products such as RF radio equipment can produce an elevated level of electromagnetic radiation. Considering that unborn babies require increased protection, pregnant women must be protected by appropriate measures. Persons with pacemakers may also be exposed to risks from electromagnetic radiation. The employer/operator must evaluate workplaces where there is a special risk of exposure to radiation and, if necessary, take measures to avert the potential danger.
6. Should a fire occur, the product may release hazardous substances (gases, fluids, etc.) that can cause health problems. Therefore, suitable measures must be taken, e.g. protective masks and protective clothing must be worn.
7. If a laser product (e.g. a CD/DVD drive) is integrated into a Rohde & Schwarz product, absolutely no other settings or functions may be used as described in the product documentation. The objective is to prevent personal injury (e.g. due to laser beams).

Repair and service

1. The product may be opened only by authorized, specially trained personnel. Before any work is performed on the product or before the product is opened, it must be disconnected from the AC supply network. Otherwise, personnel will be exposed to the risk of an electric shock.
2. Adjustments, replacement of parts, maintenance and repair may be performed only by electrical experts authorized by Rohde & Schwarz. Only original parts may be used for replacing parts relevant to safety (e.g. power switches, power transformers, fuses). A safety test must always be performed after parts relevant to safety have been replaced (visual inspection, PE conductor test, insulation resistance measurement, leakage current measurement, functional test). This helps ensure the continued safety of the product.

Batteries and rechargeable batteries/cells

If the information regarding batteries and rechargeable batteries/cells is not observed either at all or to the extent necessary, product users may be exposed to the risk of explosions, fire and/or serious personal injury, and, in some cases, death. Batteries and rechargeable batteries with alkaline electrolytes (e.g. lithium cells) must be handled in accordance with the EN 62133 standard.

1. Cells must not be taken apart or crushed.
2. Cells or batteries must not be exposed to heat or fire. Storage in direct sunlight must be avoided. Keep cells and batteries clean and dry. Clean soiled connectors using a dry, clean cloth.
3. Cells or batteries must not be short-circuited. Cells or batteries must not be stored in a box or in a drawer where they can short-circuit each other, or where they can be short-circuited by other conductive materials. Cells and batteries must not be removed from their original packaging until they are ready to be used.
4. Keep cells and batteries out of the hands of children. If a cell or a battery has been swallowed, seek medical aid immediately.
5. Cells and batteries must not be exposed to any mechanical shocks that are stronger than permitted.
6. If a cell develops a leak, the fluid must not be allowed to come into contact with the skin or eyes. If contact occurs, wash the affected area with plenty of water and seek medical aid.
7. Improperly replacing or charging cells or batteries that contain alkaline electrolytes (e.g. lithium cells) can cause explosions. Replace cells or batteries only with the matching Rohde & Schwarz type (see parts list) in order to ensure the safety of the product.
8. Cells and batteries must be recycled and kept separate from residual waste. Rechargeable batteries and normal batteries that contain lead, mercury or cadmium are hazardous waste. Observe the national regulations regarding waste disposal and recycling.

Transport

1. The product may be very heavy. Therefore, the product must be handled with care. In some cases, the user may require a suitable means of lifting or moving the product (e.g. with a lift-truck) to avoid back or other physical injuries.

2. Handles on the products are designed exclusively to enable personnel to transport the product. It is therefore not permissible to use handles to fasten the product to or on transport equipment such as cranes, fork lifts, wagons, etc. The user is responsible for securely fastening the products to or on the means of transport or lifting. Observe the safety regulations of the manufacturer of the means of transport or lifting. Noncompliance can result in personal injury or material damage.
3. If you use the product in a vehicle, it is the sole responsibility of the driver to drive the vehicle safely and properly. The manufacturer assumes no responsibility for accidents or collisions. Never use the product in a moving vehicle if doing so could distract the driver of the vehicle. Adequately secure the product in the vehicle to prevent injuries or other damage in the event of an accident.

Waste disposal

1. If products or their components are mechanically and/or thermally processed in a manner that goes beyond their intended use, hazardous substances (heavy-metal dust such as lead, beryllium, nickel) may be released. For this reason, the product may only be disassembled by specially trained personnel. Improper disassembly may be hazardous to your health. National waste disposal regulations must be observed.
2. If handling the product releases hazardous substances or fuels that must be disposed of in a special way, e.g. coolants or engine oils that must be replenished regularly, the safety instructions of the manufacturer of the hazardous substances or fuels and the applicable regional waste disposal regulations must be observed. Also observe the relevant safety instructions in the product documentation. The improper disposal of hazardous substances or fuels can cause health problems and lead to environmental damage.

Informaciones elementales de seguridad

Es imprescindible leer y observar las siguientes instrucciones e informaciones de seguridad!









El principio del grupo de empresas Rohde & Schwarz consiste en tener nuestros productos siempre al día con los estándares de seguridad y de ofrecer a nuestros clientes el máximo grado de seguridad. Nuestros productos y todos los equipos adicionales son siempre fabricados y examinados según las normas de seguridad vigentes. Nuestro sistema de garantía de calidad controla constantemente que sean cumplidas estas normas. El presente producto ha sido fabricado y examinado según el certificado de conformidad adjunto de la UE y ha salido de nuestra planta en estado impecable según los estándares técnicos de seguridad. Para poder preservar este estado y garantizar un funcionamiento libre de peligros, el usuario deberá atenerse a todas las indicaciones, informaciones de seguridad y notas de alerta. El grupo de empresas Rohde & Schwarz está siempre a su disposición en caso de que tengan preguntas referentes a estas informaciones de seguridad.







Además queda en la responsabilidad del usuario utilizar el producto en la forma debida. Este producto está destinado exclusivamente al uso en la industria y el laboratorio o, si ha sido expresamente autorizado, para aplicaciones de campo y de ninguna manera deberá ser utilizado de modo que alguna persona/cosa pueda sufrir daño. El uso del producto fuera de sus fines definidos o sin tener en cuenta las instrucciones del fabricante queda en la responsabilidad del usuario. El fabricante no se hace en ninguna forma responsable de consecuencias a causa del mal uso del producto.

Se parte del uso correcto del producto para los fines definidos si el producto es utilizado conforme a las indicaciones de la correspondiente documentación del producto y dentro del margen de rendimiento definido (ver hoja de datos, documentación, informaciones de seguridad que siguen). El uso del producto hace necesarios conocimientos técnicos y ciertos conocimientos del idioma inglés. Por eso se debe tener en cuenta que el producto solo pueda ser operado por personal especializado o personas instruidas en profundidad con las capacidades correspondientes. Si fuera necesaria indumentaria de seguridad para el uso de productos de Rohde & Schwarz, encontraría la información debida en la documentación del producto en el capítulo correspondiente. Guarde bien las informaciones de seguridad elementales, así como la documentación del producto, y entréguelas a usuarios posteriores.

Tener en cuenta las informaciones de seguridad sirve para evitar en lo posible lesiones o daños por peligros de toda clase. Por eso es imprescindible leer detalladamente y comprender por completo las siguientes informaciones de seguridad antes de usar el producto, y respetarlas durante el uso del producto. Deberán tenerse en cuenta todas las demás informaciones de seguridad, como p. ej. las referentes a la protección de personas, que encontrarán en el capítulo correspondiente de la documentación del producto y que también son de obligado cumplimiento. En las presentes informaciones de seguridad se recogen todos los objetos que distribuye el grupo de empresas Rohde & Schwarz bajo la denominación de "producto", entre ellos también aparatos, instalaciones así como toda clase de accesorios.

Símbolos y definiciones de seguridad

							
Aviso: punto de peligro general Observar la documentación del producto	Atención en el manejo de dispositivos de peso elevado	Peligro de choque eléctrico	Advertencia: superficie caliente	Conexión a conductor de protección	Conexión a tierra	Conexión a masa	Aviso: Cuidado en el manejo de dispositivos sensibles a la electrostática (ESD)

					
Tensión de alimentación de PUESTA EN MARCHA / PARADA	Indicación de estado de espera (Standby)	Corriente continua (DC)	Corriente alterna (AC)	Corriente continua / Corriente alterna (DC/AC)	El aparato está protegido en su totalidad por un aislamiento doble (reforzado)

Palabras de señal y su significado

En la documentación del producto se utilizan las siguientes palabras de señal con el fin de advertir contra riesgos y peligros.



PELIGRO identifica un peligro inminente con riesgo elevado que provocará muerte o lesiones graves si no se evita.



ADVERTENCIA identifica un posible peligro con riesgo medio de provocar muerte o lesiones (graves) si no se evita.



ATENCIÓN identifica un peligro con riesgo reducido de provocar lesiones leves o moderadas si no se evita.



AVISO indica la posibilidad de utilizar mal el producto y, como consecuencia, dañarlo.

En la documentación del producto se emplea de forma sinónima el término CUIDADO.

Las palabras de señal corresponden a la definición habitual para aplicaciones civiles en el área económica europea. Pueden existir definiciones diferentes a esta definición en otras áreas económicas o en aplicaciones militares. Por eso se deberá tener en cuenta que las palabras de señal aquí descritas sean utilizadas siempre solamente en combinación con la correspondiente documentación del producto y solamente en combinación con el producto correspondiente. La utilización de las palabras de señal en combinación con productos o documentaciones que no les correspondan puede llevar a interpretaciones equivocadas y tener por consecuencia daños en personas u objetos.

Estados operativos y posiciones de funcionamiento

El producto solamente debe ser utilizado según lo indicado por el fabricante respecto a los estados operativos y posiciones de funcionamiento sin que se obstruya la ventilación. Si no se siguen las indicaciones del fabricante, pueden producirse choques eléctricos, incendios y/o lesiones graves con posible consecuencia de muerte. En todos los trabajos deberán ser tenidas en cuenta las normas nacionales y locales de seguridad del trabajo y de prevención de accidentes.

1. Si no se convino de otra manera, es para los productos Rohde & Schwarz válido lo que sigue: como posición de funcionamiento se define por principio la posición con el suelo de la caja para abajo, modo de protección IP 2X, grado de suciedad 2, categoría de sobrecarga eléctrica 2, uso solamente en estancias interiores, utilización hasta 2000 m sobre el nivel del mar, transporte hasta 4500 m sobre el nivel del mar. Se aplicará una tolerancia de $\pm 10\%$ sobre el voltaje nominal y de $\pm 5\%$ sobre la frecuencia nominal.
2. No sitúe el producto encima de superficies, vehículos, estantes o mesas, que por sus características de peso o de estabilidad no sean aptos para él. Siga siempre las instrucciones de instalación del fabricante cuando instale y asegure el producto en objetos o estructuras (p. ej. paredes y estantes). Si se realiza la instalación de modo distinto al indicado en la documentación del producto, pueden causarse lesiones o incluso la muerte.
3. No ponga el producto sobre aparatos que generen calor (p. ej. radiadores o calefactores). La temperatura ambiente no debe superar la temperatura máxima especificada en la documentación del producto o en la hoja de datos. En caso de sobrecalentamiento del producto, pueden producirse choques eléctricos, incendios y/o lesiones graves con posible consecuencia de muerte.

Seguridad eléctrica

Si no se siguen (o se siguen de modo insuficiente) las indicaciones del fabricante en cuanto a seguridad eléctrica, pueden producirse choques eléctricos, incendios y/o lesiones graves con posible consecuencia de muerte.

1. Antes de la puesta en marcha del producto se deberá comprobar siempre que la tensión preseleccionada en el producto coincida con la de la red de alimentación eléctrica. Si es necesario modificar el ajuste de tensión, también se deberán cambiar en caso dado los fusibles correspondientes del producto.
2. Los productos de la clase de protección I con alimentación móvil y enchufe individual solamente podrán enchufarse a tomas de corriente con contacto de seguridad y con conductor de protección conectado.
3. Queda prohibida la interrupción intencionada del conductor de protección, tanto en la toma de corriente como en el mismo producto. La interrupción puede tener como consecuencia el riesgo de que el producto sea fuente de choques eléctricos. Si se utilizan cables alargadores o regletas de enchufe, deberá garantizarse la realización de un examen regular de los mismos en cuanto a su estado técnico de seguridad.
4. Si el producto no está equipado con un interruptor para desconectarlo de la red, se deberá considerar el enchufe del cable de conexión como interruptor. En estos casos se deberá asegurar que el enchufe siempre sea de fácil acceso (de acuerdo con la longitud del cable de conexión, aproximadamente 2 m). Los interruptores de función o electrónicos no son aptos para el corte de la red eléctrica. Si los productos sin interruptor están integrados en bastidores o instalaciones, se deberá colocar el interruptor en el nivel de la instalación.
5. No utilice nunca el producto si está dañado el cable de conexión a red. Compruebe regularmente el correcto estado de los cables de conexión a red. Asegúrese, mediante las medidas de protección y de instalación adecuadas, de que el cable de conexión a red no pueda ser dañado o de que nadie pueda ser dañado por él, p. ej. al tropezar o por un choque eléctrico.
6. Solamente está permitido el funcionamiento en redes de alimentación TN/TT aseguradas con fusibles de 16 A como máximo (utilización de fusibles de mayor amperaje solo previa consulta con el grupo de empresas Rohde & Schwarz).
7. Nunca conecte el enchufe en tomas de corriente sucias o llenas de polvo. Introduzca el enchufe por completo y fuertemente en la toma de corriente. La no observación de estas medidas puede provocar chispas, fuego y/o lesiones.
8. No sobrecargue las tomas de corriente, los cables alargadores o las regletas de enchufe ya que esto podría causar fuego o choques eléctricos.
9. En las mediciones en circuitos de corriente con una tensión $U_{\text{eff}} > 30 \text{ V}$ se deberán tomar las medidas apropiadas para impedir cualquier peligro (p. ej. medios de medición adecuados, seguros, limitación de tensión, corte protector, aislamiento etc.).
10. Para la conexión con dispositivos informáticos como un PC o un ordenador industrial, debe comprobarse que éstos cumplan los estándares IEC60950-1/EN60950-1 o IEC61010-1/EN 61010-1 válidos en cada caso.
11. A menos que esté permitido expresamente, no retire nunca la tapa ni componentes de la carcasa mientras el producto esté en servicio. Esto pone a descubierto los cables y componentes eléctricos y puede causar lesiones, fuego o daños en el producto.

12. Si un producto se instala en un lugar fijo, se deberá primero conectar el conductor de protección fijo con el conductor de protección del producto antes de hacer cualquier otra conexión. La instalación y la conexión deberán ser efectuadas por un electricista especializado.
13. En el caso de dispositivos fijos que no estén provistos de fusibles, interruptor automático ni otros mecanismos de seguridad similares, el circuito de alimentación debe estar protegido de modo que todas las personas que puedan acceder al producto, así como el producto mismo, estén a salvo de posibles daños.
14. Todo producto debe estar protegido contra sobretensión (debida p. ej. a una caída del rayo) mediante los correspondientes sistemas de protección. Si no, el personal que lo utilice quedará expuesto al peligro de choque eléctrico.
15. No debe introducirse en los orificios de la caja del aparato ningún objeto que no esté destinado a ello. Esto puede producir cortocircuitos en el producto y/o puede causar choques eléctricos, fuego o lesiones.
16. Salvo indicación contraria, los productos no están impermeabilizados (ver también el capítulo "Estados operativos y posiciones de funcionamiento", punto 1). Por eso es necesario tomar las medidas necesarias para evitar la entrada de líquidos. En caso contrario, existe peligro de choque eléctrico para el usuario o de daños en el producto, que también pueden redundar en peligro para las personas.
17. No utilice el producto en condiciones en las que pueda producirse o ya se hayan producido condensaciones sobre el producto o en el interior de éste, como p. ej. al desplazarlo de un lugar frío a otro caliente. La entrada de agua aumenta el riesgo de choque eléctrico.
18. Antes de la limpieza, desconecte por completo el producto de la alimentación de tensión (p. ej. red de alimentación o batería). Realice la limpieza de los aparatos con un paño suave, que no se deshilache. No utilice bajo ningún concepto productos de limpieza químicos como alcohol, acetona o diluyentes para lacas nitrocelulósicas.

Funcionamiento

1. El uso del producto requiere instrucciones especiales y una alta concentración durante el manejo. Debe asegurarse que las personas que manejen el producto estén a la altura de los requerimientos necesarios en cuanto a aptitudes físicas, psíquicas y emocionales, ya que de otra manera no se pueden excluir lesiones o daños de objetos. El empresario u operador es responsable de seleccionar el personal usuario apto para el manejo del producto.
2. Antes de desplazar o transportar el producto, lea y tenga en cuenta el capítulo "Transporte".
3. Como con todo producto de fabricación industrial no puede quedar excluida en general la posibilidad de que se produzcan alergias provocadas por algunos materiales empleados, los llamados alérgenos (p. ej. el níquel). Si durante el manejo de productos Rohde & Schwarz se producen reacciones alérgicas, como p. ej. irritaciones cutáneas, estornudos continuos, enrojecimiento de la conjuntiva o dificultades respiratorias, debe avisarse inmediatamente a un médico para investigar las causas y evitar cualquier molestia o daño a la salud.
4. Antes de la manipulación mecánica y/o térmica o el desmontaje del producto, debe tenerse en cuenta imprescindiblemente el capítulo "Eliminación", punto 1.

5. Ciertos productos, como p. ej. las instalaciones de radiocomunicación RF, pueden a causa de su función natural, emitir una radiación electromagnética aumentada. Deben tomarse todas las medidas necesarias para la protección de las mujeres embarazadas. También las personas con marcapasos pueden correr peligro a causa de la radiación electromagnética. El empresario/operador tiene la obligación de evaluar y señalar las áreas de trabajo en las que exista un riesgo elevado de exposición a radiaciones.
6. Tenga en cuenta que en caso de incendio pueden desprenderse del producto sustancias tóxicas (gases, líquidos etc.) que pueden generar daños a la salud. Por eso, en caso de incendio deben usarse medidas adecuadas, como p. ej. máscaras antigás e indumentaria de protección.
7. En caso de que un producto Rohde & Schwarz contenga un producto láser (p. ej. un lector de CD/DVD), no debe usarse ninguna otra configuración o función aparte de las descritas en la documentación del producto, a fin de evitar lesiones (p. ej. debidas a irradiación láser).

Reparación y mantenimiento

1. El producto solamente debe ser abierto por personal especializado con autorización para ello. Antes de manipular el producto o abrirlo, es obligatorio desconectarlo de la tensión de alimentación, para evitar toda posibilidad de choque eléctrico.
2. El ajuste, el cambio de partes, el mantenimiento y la reparación deberán ser efectuadas solamente por electricistas autorizados por Rohde & Schwarz. Si se reponen partes con importancia para los aspectos de seguridad (p. ej. el enchufe, los transformadores o los fusibles), solamente podrán ser sustituidos por partes originales. Después de cada cambio de partes relevantes para la seguridad deberá realizarse un control de seguridad (control a primera vista, control del conductor de protección, medición de resistencia de aislamiento, medición de la corriente de fuga, control de funcionamiento). Con esto queda garantizada la seguridad del producto.

Baterías y acumuladores o celdas

Si no se siguen (o se siguen de modo insuficiente) las indicaciones en cuanto a las baterías y acumuladores o celdas, pueden producirse explosiones, incendios y/o lesiones graves con posible consecuencia de muerte. El manejo de baterías y acumuladores con electrolitos alcalinos (p. ej. celdas de litio) debe seguir el estándar EN 62133.

1. No deben desmontarse, abrirse ni triturarse las celdas.
2. Las celdas o baterías no deben someterse a calor ni fuego. Debe evitarse el almacenamiento a la luz directa del sol. Las celdas y baterías deben mantenerse limpias y secas. Limpiar las conexiones sucias con un paño seco y limpio.
3. Las celdas o baterías no deben cortocircuitarse. Es peligroso almacenar las celdas o baterías en estuches o cajones en cuyo interior puedan cortocircuitarse por contacto recíproco o por contacto con otros materiales conductores. No deben extraerse las celdas o baterías de sus embalajes originales hasta el momento en que vayan a utilizarse.
4. Mantener baterías y celdas fuera del alcance de los niños. En caso de ingestión de una celda o batería, avisar inmediatamente a un médico.
5. Las celdas o baterías no deben someterse a impactos mecánicos fuertes indebidos.

6. En caso de falta de estanqueidad de una celda, el líquido vertido no debe entrar en contacto con la piel ni los ojos. Si se produce contacto, lavar con agua abundante la zona afectada y avisar a un médico.
7. En caso de cambio o recarga inadecuados, las celdas o baterías que contienen electrolitos alcalinos (p. ej. las celdas de litio) pueden explotar. Para garantizar la seguridad del producto, las celdas o baterías solo deben ser sustituidas por el tipo Rohde & Schwarz correspondiente (ver lista de recambios).
8. Las baterías y celdas deben reciclarse y no deben tirarse a la basura doméstica. Las baterías o acumuladores que contienen plomo, mercurio o cadmio deben tratarse como residuos especiales. Respete en esta relación las normas nacionales de eliminación y reciclaje.

Transporte

1. El producto puede tener un peso elevado. Por eso es necesario desplazarlo o transportarlo con precaución y, si es necesario, usando un sistema de elevación adecuado (p. ej. una carretilla elevadora), a fin de evitar lesiones en la espalda u otros daños personales.
2. Las asas instaladas en los productos sirven solamente de ayuda para el transporte del producto por personas. Por eso no está permitido utilizar las asas para la sujeción en o sobre medios de transporte como p. ej. grúas, carretillas elevadoras de horquilla, carros etc. Es responsabilidad suya fijar los productos de manera segura a los medios de transporte o elevación. Para evitar daños personales o daños en el producto, siga las instrucciones de seguridad del fabricante del medio de transporte o elevación utilizado.
3. Si se utiliza el producto dentro de un vehículo, recae de manera exclusiva en el conductor la responsabilidad de conducir el vehículo de manera segura y adecuada. El fabricante no asumirá ninguna responsabilidad por accidentes o colisiones. No utilice nunca el producto dentro de un vehículo en movimiento si esto pudiera distraer al conductor. Asegure el producto dentro del vehículo debidamente para evitar, en caso de un accidente, lesiones u otra clase de daños.

Eliminación

1. Si se trabaja de manera mecánica y/o térmica cualquier producto o componente más allá del funcionamiento previsto, pueden liberarse sustancias peligrosas (polvos con contenido de metales pesados como p. ej. plomo, berilio o níquel). Por eso el producto solo debe ser desmontado por personal especializado con formación adecuada. Un desmontaje inadecuado puede ocasionar daños para la salud. Se deben tener en cuenta las directivas nacionales referentes a la eliminación de residuos.
2. En caso de que durante el trato del producto se formen sustancias peligrosas o combustibles que deban tratarse como residuos especiales (p. ej. refrigerantes o aceites de motor con intervalos de cambio definidos), deben tenerse en cuenta las indicaciones de seguridad del fabricante de dichas sustancias y las normas regionales de eliminación de residuos. Tenga en cuenta también en caso necesario las indicaciones de seguridad especiales contenidas en la documentación del producto. La eliminación incorrecta de sustancias peligrosas o combustibles puede causar daños a la salud o daños al medio ambiente.

Qualitätszertifikat

Certificate of quality

Certificat de qualité

Certified Quality System
ISO 9001

Certified Environmental System
ISO 14001

Sehr geehrter Kunde,

Sie haben sich für den Kauf eines Rohde&Schwarz-Produktes entschieden. Hiermit erhalten Sie ein nach modernsten Fertigungsmethoden hergestelltes Produkt. Es wurde nach den Regeln unseres Qualitätsmanagementsystems entwickelt, gefertigt und geprüft. Das Rohde&Schwarz-Qualitätsmanagementsystem ist u.a. nach ISO9001 und ISO 14001 zertifiziert.

Der Umwelt verpflichtet

- ▮ Energie-effiziente, RoHS-konforme Produkte
- ▮ Kontinuierliche Weiterentwicklung nachhaltiger Umweltkonzepte
- ▮ ISO 14001-zertifiziertes Umweltmanagementsystem

Dear Customer,

You have decided to buy a Rohde&Schwarz product. You are thus assured of receiving a product that is manufactured using the most modern methods available. This product was developed, manufactured and tested in compliance with our quality management system standards. The Rohde&Schwarz quality management system is certified according to standards such as ISO9001 and ISO 14001.

Environmental commitment

- ▮ Energy-efficient products
- ▮ Continuous improvement in environmental sustainability
- ▮ ISO 14001-certified environmental management system

Cher client,

Vous avez choisi d'acheter un produit Rohde&Schwarz. Vous disposez donc d'un produit fabriqué d'après les méthodes les plus avancées. Le développement, la fabrication et les tests respectent nos normes de gestion qualité. Le système de gestion qualité de Rohde&Schwarz a été homologué, entre autres, conformément aux normes ISO9001 et ISO 14001.

Engagement écologique

- ▮ Produits à efficience énergétique
- ▮ Amélioration continue de la durabilité environnementale
- ▮ Système de gestion de l'environnement certifié selon ISO 14001

Customer Support

Technical support – where and when you need it

For quick, expert help with any Rohde & Schwarz equipment, contact one of our Customer Support Centers. A team of highly qualified engineers provides telephone support and will work with you to find a solution to your query on any aspect of the operation, programming or applications of Rohde & Schwarz equipment.

Up-to-date information and upgrades

To keep your instrument up-to-date and to be informed about new application notes related to your instrument, please send an e-mail to the Customer Support Center stating your instrument and your wish. We will take care that you will get the right information.

USA & Canada

Monday to Friday (except US public holidays)
8:00 AM – 8:00 PM Eastern Standard Time (EST)

Tel. from USA 888-test-rsa (888-837-8772) (opt 2)
From outside USA +1 410 910 7800 (opt 2)
Fax +1 410 910 7801

E-mail CustomerSupport@rohde-schwarz.com

East Asia

Monday to Friday (except Singaporean public holidays)
8:30 AM – 6:00 PM Singapore Time (SGT)

Tel. +65 6 513 0488
Fax +65 6 846 1090

E-mail CustomerSupport@rohde-schwarz.com

Rest of the World

Monday to Friday (except German public holidays)
08:00 – 17:00 Central European Time (CET)

Tel. +49 89 4129 13774
Fax +49 (0) 89 41 29 637 78

E-mail CustomerSupport@rohde-schwarz.com



ROHDE & SCHWARZ

Address List

Headquarters, Plants and Subsidiaries

Headquarters

ROHDE & SCHWARZ GmbH & Co. KG
Mühlendorfstraße 15 · D-81671 München
P.O.Box 80 14 69 · D-81614 München

Phone +49 (89) 41 29-0
Fax +49 (89) 41 29-121 64
info.rs@rohde-schwarz.com

Plants

ROHDE & SCHWARZ Messgerätebau GmbH
Riedbachstraße 58 · D-87700 Memmingen
P.O.Box 16 52 · D-87686 Memmingen

Phone +49 (83 31) 1 08-0
+49 (83 31) 1 08-1124
info.rsmb@rohde-schwarz.com

ROHDE & SCHWARZ GmbH & Co. KG
Werk Teisnach
Kaikenrieder Straße 27 · D-94244 Teisnach
P.O.Box 11 49 · D-94240 Teisnach

Phone +49 (99 23) 8 50-0
Fax +49 (99 23) 8 50-174
info.rsdt@rohde-schwarz.com

ROHDE & SCHWARZ závod
Vimperk, s.r.o.
Location Spidrova 49
CZ-38501 Vimperk

Phone +420 (388) 45 21 09
Fax +420 (388) 45 21 13

ROHDE & SCHWARZ GmbH & Co. KG
Dienstleistungszentrum Köln
Graf-Zeppelin-Straße 18 · D-51147 Köln
P.O.Box 98 02 60 · D-51130 Köln

Phone +49 (22 03) 49-0
Fax +49 (22 03) 49 51-229
info.rsdc@rohde-schwarz.com
service.rsdc@rohde-schwarz.com

Subsidiaries

R&S BICK Mobilfunk GmbH
Fritz-Hahne-Str. 7 · D-31848 Bad Münder
P.O.Box 20 02 · D-31844 Bad Münder

Phone +49 (50 42) 9 98-0
Fax +49 (50 42) 9 98-105
info.bick@rohde-schwarz.com

ROHDE & SCHWARZ FTK GmbH
Wendenschloßstraße 168, Haus 28
D-12557 Berlin

Phone +49 (30) 658 91-122
Fax +49 (30) 655 50-221
info.ftk@rohde-schwarz.com

ROHDE & SCHWARZ SIT GmbH
Am Studio 3
D-12489 Berlin

Phone +49 (30) 658 84-0
Fax +49 (30) 658 84-183
info.sit@rohde-schwarz.com

R&S Systems GmbH
Graf-Zeppelin-Straße 18
D-51147 Köln

Phone +49 (22 03) 49-5 23 25
Fax +49 (22 03) 49-5 23 36
info.rssys@rohde-schwarz.com

GEDIS GmbH
Sophienblatt 100
D-24114 Kiel

Phone +49 (431) 600 51-0
Fax +49 (431) 600 51-11
sales@gedis-online.de

HAMEG Instruments GmbH
Industriestraße 6
D-63533 Mainhausen

Phone +49 (61 82) 800-0
Fax +49 (61 82) 800-100
info@hameg.de

Locations Worldwide

Please refer to our homepage: www.rohde-schwarz.com

- ◆ Sales Locations
- ◆ Service Locations
- ◆ National Websites

Contents

Safety Instructions
 Certificate of Quality
 Support Center Address
 List of R&S Representatives

Contents of Manual for Application Firmware R&S FS–K76

TD–SCDMA Base Station Test Application Firmware R&S FS–K76	7
1 Installing and Enabling Application Firmware	8
Installation	8
Enabling	8
2 Getting Started	9
Generating TD–SCDMA signal with R&S WinIQSIM	10
Basic settings in TD–SCDMA BTS mode	13
Measurement 1: Measuring signal power	14
Measurement 2: Measuring spectrum emission mask	15
Measurement 3: Measuring relative code domain power and frequency error	16
Setting: Synchronizing reference frequencies	17
Setting: Response to deviating center frequency setting	17
Setting: Response to wrong scrambling code	18
Measurement 4: Measuring composite EVM	19
Measurement 5: Measuring peak code domain error	20
Measurement 6: Measuring RHO factor	21
3 Setup for Base Station Tests	22
Standard test setup	22
Default setting	23
4 Menu Overview	24
5 Configuration of TD–SCDMA Measurements	27
Measurement of channel power	28
Measurement of adjacent channel power – ACLR	30
Menu MEAS – MULT CARR ACLR	36
Checking signal power – SPECTRUM EM MASK	40
3GPP standard: Spectrum Emission Mask	42
TSM standard: Spectrum Emission Mask	43
Measurement of bandwidth occupied by signal – OCCUPIED BANDWIDTH	47
Signal power versus time – POWER VS TIME	49
Signal statistic	51
Code domain measurements on TD–SCDMA signals	55
Presentation of evaluations – RESULTS	57
Configuration of measurements	73
Configuration of application firmware – SETTINGS	78
Frequency setting – <i>FREQ</i> key	82
Span settings – <i>SPAN</i> key	82
Level settings – <i>AMPT</i> key	83
Marker settings – <i>MKR</i> key	84
Marker settings – <i>MKR</i> → key	85

Marker functions – <i>MKR FCTN</i> key	86
Bandwidth setting – <i>BW</i> key	86
Measurement control – <i>SWEEP</i> key.....	86
Measurement selection – <i>MEAS</i> key	86
Trigger settings – <i>TRIG</i> key	87
Trace settings – <i>TRACE</i> key.....	87
Display lines – <i>LINES</i> key	88
Measurement screen settings – <i>DISP</i> key.....	88
Storing and loading unit data – <i>FILE</i> key	88
Preset of device – <i>PRESET</i> key	88
Calibration of device – <i>CAL</i> key.....	88
Setup of device – <i>SETUP</i> key.....	89
Printing – <i>HCOPY</i> key.....	89
6 Remote Control Commands.....	90
CALCulate:FEED subsystem	90
CALCulate:LIMit: ESPectrum subsystem	92
CALCulate:MARKer subsystem	94
CALCulate:PEAKsearch PSEarch subsystem.....	96
CONFigure:CDPower subsystem	97
INSTrument subsystem.....	102
SENSe:CDPower subsystem.....	103
SENSe:Power subsystem	108
TRACe subsystem	113
STATus:QUESTionable:SYNC register	118
Table of softkeys with assignment of IEC/IEEE bus commands	119
<i>MEAS</i> key or <i>MEAS</i> hotkey	119
<i>RESULTS</i> hotkey or <i>CODE DOM ANALYZER</i> softkey	124
<i>CHAN CONF</i> hotkey	126
<i>SETTINGS</i> hotkey.....	127
7 Checking Rated Specifications	128
Measuring equipment and accessories	128
Test sequence.....	129
8 Glossary	131
9 Index	132

Figures

Fig. 2–1	R&S WinIQSIM – TD–SCDMA configuration	10
Fig. 2–2	R&S WinIQSIM – transmit filter settings	10
Fig. 2–3	R&S WinIQSIM – subframe configuration	11
Fig. 2–4	R&S WinIQSIM – channel settings in slot 0	11
Fig. 2–5	R&S WinIQSIM – channel settings in slots 4–6	12
Fig. 2–6	R&S WinIQSIM – trigger settings	12
Fig. 3–1	BTS test setup	22
Fig. 4–1	Hotkey bar with enabled Application Firmware R&S FS–K76	24
Fig. 4–2	Overview of menus in Application Firmware R&S FS–K76	24
Fig. 4–3	Overview of menus.....	26
Fig. 5–1	Power measurement over 1.6 MHz bandwidth	28
Fig. 5–2	Measuring adjacent channel power.....	30
Fig. 5–3	Measurement of spectrum emission mask (3GPP).....	40
Fig. 5–4	Measuring occupied bandwidth.....	47
Fig. 5–5	Measuring signal power versus time	49
Fig. 5–6	CCDF of TD–SCDMA signal.	51
Fig. 5–7	Function fields of diagrams	58
Fig. 5–8	CDP diagram	59
Fig. 5–9	CDEP diagram.....	60
Fig. 5–10	Composite EVM diagram	61
Fig. 5–11	Composite EVM diagram with unrecognized channels.....	61
Fig. 5–12	Peak code domain error diagram	62
Fig. 5–13	Peak code domain error diagram with unrecognized channels	62
Fig. 5–14	Peak versus slot diagram with absolute power readout.....	63
Fig. 5–15	Result summary.....	64
Fig. 5–16	Channel table in code order	66
Fig. 5–17	Channel table in midamble order	67
Fig. 5–18	Symbol constellation diagram for 8PSK modulation	68
Fig. 5–19	Error vector magnitude for one channel of slot	68
Fig. 5–20	Phasor diagram for QPSK and 8PSK including bit values.....	69
Fig. 5–21	Demodulated bits for channel with 8PSK modulation	69
Bild 5–22	Composite Constellation Diagram.....	70
Fig. 5–23	Power versus symbol for one channel of one slot.....	70
Fig. 5–24	Table for editing channel configuration	74
Fig. 5–25	Table of special channels	76
Fig. 5–26	Creating new channel configuration	77
Fig. 5–27	Marker field of CDP measurement.....	84

Tables

Table 2–1	Default settings of code domain measurement after preset	13
Table 5–1	Default ACLR settings	31
Table 5–2	Maximum output power $P < 26$ dBm	42
Table 5–3	Maximum output power 26 dBm $\leq P < 34$ dBm	42
Table 5–4	Maximum Output power $P \geq 34$ dBm	42
Tabelle 5–5	Maximum output power $P < 31$ dBm	43
Tabelle 5–6	Maximum output power 31 dBm $\leq P < 39$ dBm	43
Tabelle 5–7	Maximum output power 39 dBm $\leq P < 43$ dBm	43
Tabelle 5–8	Maximum output power $P \geq 43$ dBm	43
Table 5–9	Evaluation on screen A	55
Table 5–10	Evaluation on screen B	55
Table 5–11	Relationship between spreading factor and symbol count plus data rate.....	56
Table 6–1	Meaning of bits in STATus:QUEstionable:SYNC register.....	118

Contents of Application Firmware R&S FS–K76 Software Manual

This software manual contains information on operation of the Spectrum Analyzer R&S FSU, R&S FSP or Signal Analyzer R&S FSQ configured with the Application Firmware R&S FS–K76. It includes a description of the menus and remote control commands for the TD–SCDMA base station test application firmware.

All other details of analyzer operation can be found in the relevant operating manual.

The software manual of the application firmware consists of a data sheet and nine chapters:

Data Sheet	details guaranteed and typical specifications and firmware characteristics.
Chapter 1	describes how to enable the application firmware.
Chapter 2	describes typical measurements by test examples.
Chapter 3	describes the measurement setup for base station tests.
Chapter 4	gives a schematic overview of the operating menus.
Chapter 5	contains a detailed description of all functions for base station tests as a reference for manual operation. The chapter also lists the corresponding IEC/IEEE bus command for each function.
Chapter 6	describes all remote control commands defined for the application firmware. A table containing the IEC/IEEE bus commands assigned to the softkeys is given at the end of the chapter.
Chapter 7	describes the procedure for checking rated characteristics.
Chapter 8	explains terms relating to measured variables in code domain measurement.
Chapter 9	contains the index of this software manual.

TD-SCDMA Base Station Test Application Firmware R&S FS-K76

When configured with the Application Firmware R&S FS-K76, the analyzer performs code domain power measurements on forward link signals (base station). The measurements are based on the 3GPP (Third Generation Partnership Project) standard or alternatively on the CWTS-TSM standard (China Wireless Telecommunication Standard).

The basic standards are 3GPP TS 25.142 "Base Station Conformance Testing (TDD)", version V5.5.0, 3GPP TS 25.221 "Physical channels and mapping of transport channels onto physical channels (TDD)", version V5.5.0 and CWTS TSM 11.21 "Base Station System (BSS) equipment specification", version V3.1.0. When TD-SCDMA specifications are mentioned in the document, this standard is meant.

In addition to the measurements specified by the TD-SCDMA standard in the code domain, the application firmware features measurements in the spectral range such as channel power, adjacent channel power, occupied bandwidth and spectrum emission mask with predefined settings.

1 Installing and Enabling Application Firmware

Installation

If the Application Firmware R&S FS-K76 is not yet installed on the unit, a firmware update is necessary. This has already been done in the case of installation at the factory.

You must install appropriate basic firmware on the analyzer to enable installation of the application firmware. Refer to the release notes of the current Application Firmware R&S FS-K76 for compatible versions.

If the basic firmware has to be updated, start the update with the floppy disks containing the basic firmware by *SETUP* → *NEXT* → *FIRMWARE UPDATE*.

If the correct basic firmware is installed, start the update for the application firmware from the floppy disks containing the Application Firmware R&S FS-K76 by the the same operation *SETUP* → *NEXT* → *FIRMWARE UPDATE*.

After installation of the application firmware, you must enable it as described below.

Enabling

The Application Firmware R&S FS-K76 is enabled in the *SETUP* → *GENERAL SETUP* menu by entering a keyword. The keyword comes with the application firmware. If the application is installed at the factory it will already be enabled.

GENERAL SETUP menu:

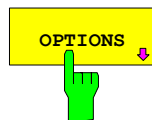

The *OPTIONS* softkey opens a submenu in which you can enter the keywords for the application firmware. The existing applications are displayed in a table that opens when you enter the submenu.



The *INSTALL OPTION* softkey enables entry of the keyword for an application firmware.

A keyword can be entered in the entry field. If the keyword is valid, the message *OPTION KEY OK* is displayed and the application firmware is entered in the *FIRMWARE OPTIONS* table.

If an invalid keyword is entered, *OPTION KEY INVALID* is displayed.

If the version of the application firmware and that of the basic firmware are not compatible, you see a corresponding message. In this case, follow the instructions in the above chapter "Installation".

2 Getting Started

The following chapter explains basic TD-SCDMA base station tests using a setup with the Signal Generator R&S SMIQ as the device under test. It describes how to avoid operating and measuring errors by correct default settings.

The measurement screen is presented in Chapter 5 for the different measurements.

Your attention is drawn to important settings exemplifying how to avoid errors during measurement. The correct setting is followed by a demonstration of the effect of an incorrect setting. The following measurements are performed:

- Measurement 1: measuring signal spectrum
- Measurement 2: measuring spectrum emission mask
- Measurement 3: measuring relative code domain power and frequency error
 - Setting: center frequency
 - Setting: scrambling code
- Measurement 4: measuring composite EVM
- Measurement 5: measuring peak code domain error
- Measurement 6: measuring RHO factor

TD-SCDMA raw data are created with the R&S WinIQSIM Software and loaded in the arbitrary waveform generator of the R&S SMIQ.

Measurements are performed with the following units and accessories:

- Spectrum Analyzer R&S FSU, R&S FSP or Signal Analyzer R&S FSQ with Application Firmware R&S FS-K76 base station test for TD-SCDMA.
- Vector Signal Generator R&S SMIQ with hardware options B11 Data Generator, B20 Modulation Coder and B60 Arbitrary Waveform Generator plus firmware version 5.70 or higher with enabled option K14 TD-SCDMA and R&S SMIQ-Z5 PARADATA BNC Adapter for an external trigger signal.
- A PC that is either connected to the R&S SMIQ by a serial cable or has an IEC/IEEE bus card and is connected to the R&S SMIQ by an IEC/IEEE bus cable. Installed on this PC is the R&S WinIQSIM Software 4.00 or higher. You can download this software from the Rohde & Schwarz Internet site <http://www.rohde-schwarz.com>.
- One coaxial cable, 50 Ω , approximately 1 m, N connector.
- Two coaxial cables, 50 Ω , approximately 1 m, BNC connector.

Generating TD-SCDMA signal with R&S WinIQSIM

You can download the R&S WinIQSIM Software from <http://www.rohde-schwarz.com> and install it on a PC. Using the R&S WinIQSIM Software you can generate TD-SCDMA signals and then transfer them to an R&S SMIQ or R&S AMIQ. In what follows you learn how to generate a test signal to TD-SCDMA specifications. You are assumed to be using R&S WinIQSIM version 4.00 or higher.

Start and select standard: Start **WinIQSIM.exe**.
In the **File** menu select **New** and in the following list **TD-SCDMA**. The **Block Diagram – TD-SCDMA** dialog appears.
Select **TD-SCDMA Configuration** to configure the TD-SCDMA signal, and the following dialog opens:

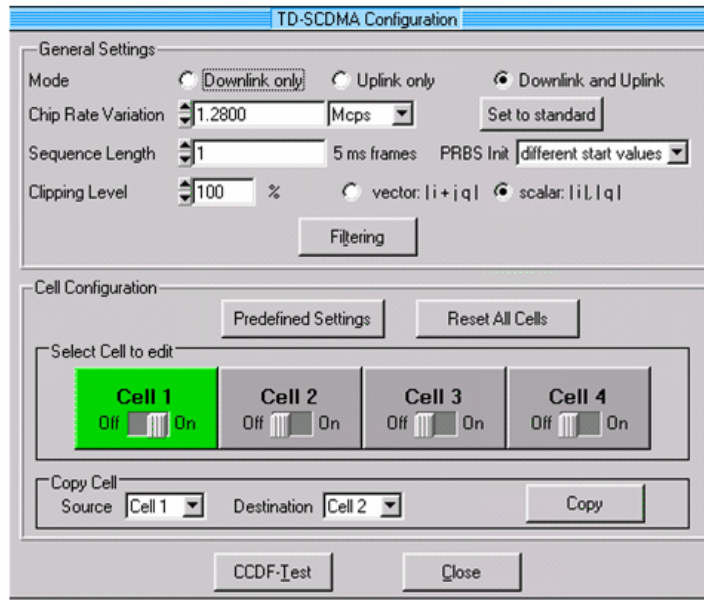

Fig. 2–1 R&S WinIQSIM – TD-SCDMA configuration

Set transmit filter:

Select **Filtering** to configure the TD-SCDMA transmit filter. Increase **Impulse Length** to 120.

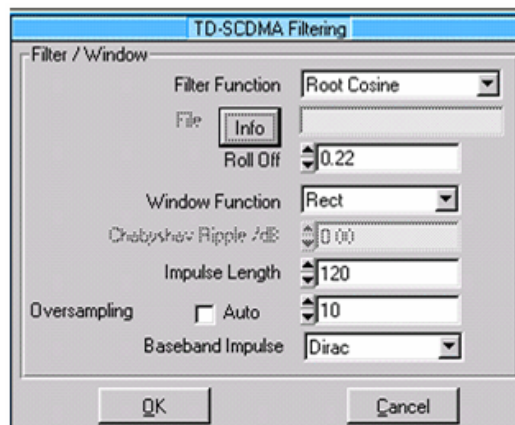

Fig. 2–2 R&S WinIQSIM – transmit filter settings

Configure subframe:

Set as follows in **TD-SCDMA Cell Configuration** for a signal with eight channels of the same power in each of the slots 4, 5 and 6. This model is

specified for some tests to TD-SCDMA standard. For synchronization you must also activate channel 1.16 in slot 0. As a rule this will be P-CCPCH.

The **Scrambling Code** must be kept on 0. Set **Mode** to **Downlink only** and select **Cell 1** to edit.

Slots 0, 4, 5 and 6 must be **On**:

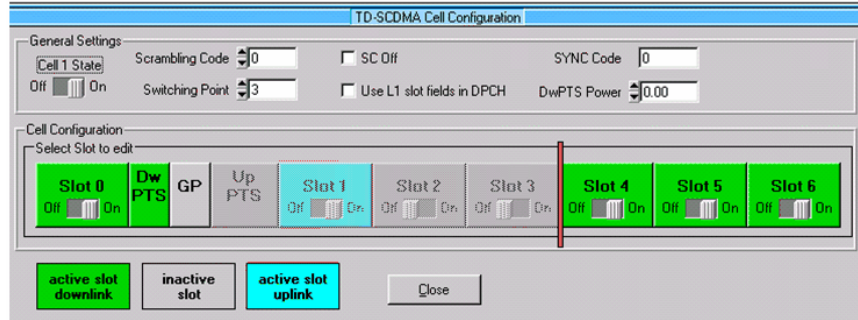

Fig. 2–3 R&S WinIQSIM – subframe configuration

Set channels:

For synchronization of the Application Software R&S FS–K76, channel 1.16 in slot 0 must be active. This corresponds to the R&S WinIQSIM settings gross data rate: 17.6 kbps (SF 16) and Spr. Code 0. The MA Shift should be set to 120 for a valid code/midamble allocation. The wrong midamble only influences the channel table, and has no effect on the other measurements or synchronization. Other channels in slot 0 are not activated. After completing your settings, normalize the power of the channels by clicking on **Adjust Total Power to 0 dB**.

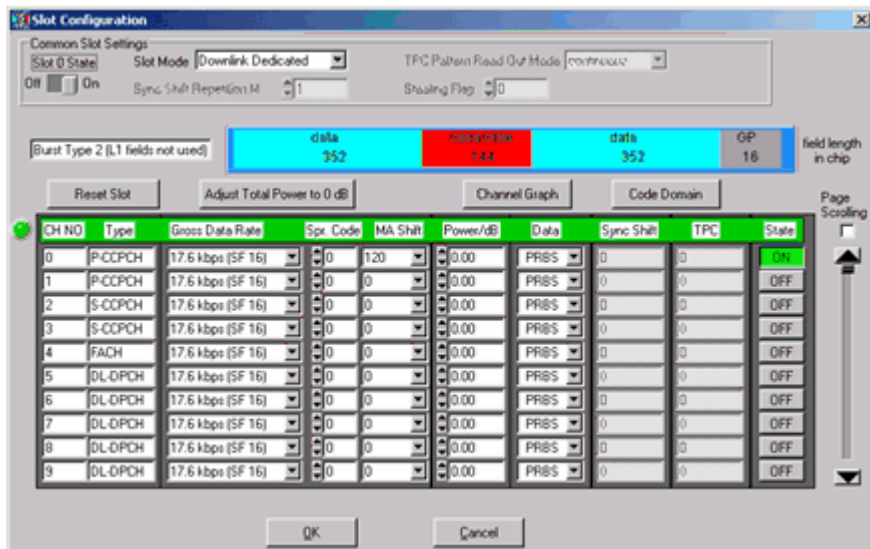

Fig. 2–4 R&S WinIQSIM – channel settings in slot 0

Note: The MA shift parameter in R&S WinIQSIM relates directly to the number of bits by which a basic midamble is cyclically shifted. This parameter does not correspond to the midamble shift parameter in TD-SCDMA specifications and in the Application Firmware R&S FS–K76 base station test for TD-SCDMA.

In each of the slots 4, 5 and 6, activate eight data channels, each with 1/8

of the total power. Allocate each channel a MA shift of 48, which corresponds to the midamble m(8) and produces a valid Common–Midamble–Allocation. After completing your settings, normalize the power of the channels by clicking on **Adjust Total Power to 0 dB**.

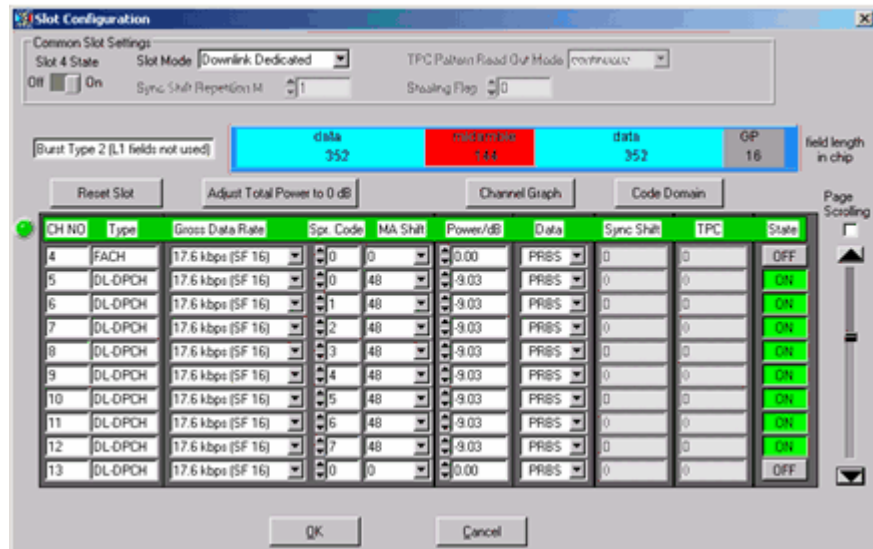

Fig. 2–5 R&S WinIQSIM – channel settings in slots 4–6

Define trigger settings:

Now you have to set the trigger settings in the **SMIQ** menu, item **Trigger Output**. **Current Mode: Restart Clock (SEQUENCE)** is defined for **Mode 1**. The trigger at the subframe limit then appears every 5 ms on TRIG1 of the R&S SMIQ Z5 BNC Adapter.

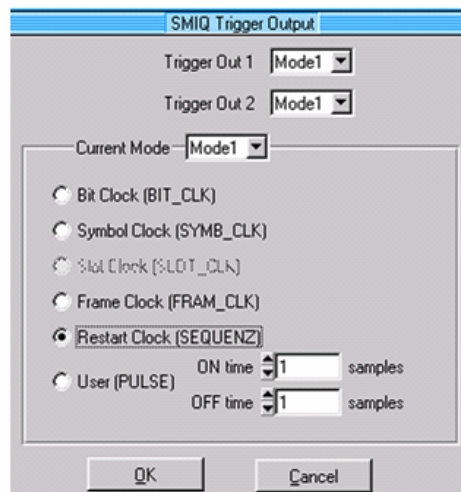

Fig. 2–6 R&S WinIQSIM – trigger settings

Save and transfer to R&S SMIQ:

Use **File|Save Settings As** to save this TD–SCDMA configuration as a file named 'TDS_BS.IQS'.

Connect the R&S SMIQ either serially or by an IEC/IEEE bus card and IEC/IEEE bus cable, and load the generated signal to the R&S SMIQ under the name 'TDS_BS' in the **SMIQ|Transmission** menu.

Basic settings in TD-SCDMA BTS mode

In the default setting after preset the analyzer is in spectrum mode. The following default settings of code domain measurement are not activated until you select TD-SCDMA BTS mode with the TDS BS hotkey.

Table 2-1 Default settings of code domain measurement after preset

Parameters	Setting
Digital standard	TD-SCDMA (3GPP)
Sweep	CONTINUOUS
CDP mode	CODE CHAN AUTOSEARCH
Trigger setting	FREE RUN
Scrambling code	0
Max. number midamble shifts	16
Threshold for inactive channel	-40 dB
Channel	1.16
Slot number	0
Capture length	7 slots
Evaluation	Screen A: CODE PWR RELATIVE Screen B: RESULT SUMMARY

The following conventions apply to the presentation of settings on the analyzer:

- [<Key>] Press a key on the front panel, e.g. [FREQ].
- [<SOFTKEY>] Press a softkey, e.g. [MARKER -> PEAK].
- [<nn unit>] Enter a value and terminate with the unit, e.g. [12 kHz].

The following conventions apply to the presentation of settings on the R&S SMIQ:

- [<Key>] Press a key on the front panel, e.g. [FREQ].
- <MENU> Select a menu, parameter or setting, e.g. *DIGITAL STD*. The menu level is identified by indenting.
- <nn unit> Enter a value and terminate with the unit, e.g. *12 kHz*.

To synchronize, you must activate channel 1.16 in slot 0.

Measurement 1: Measuring signal power

Measurement of the spectrum gives an overview of the TD-SCDMA signal and spurious emissions close to the carrier.

Test setup:

- Connect the RF output of the R&S SMIQ to the RF input of the analyzer (coaxial cable with N connectors).
- Connect the external triggering of the analyzer (EXT TRIG GATE) to the R&S SMIQ trigger (TRIGOUT1 to PARADATA).

Settings on R&S SMIQ:

```

[PRESET]
[LEVEL:           0 dBm]
[FREQ:           2020.0 MHz]
ARB MOD
  SET SMIQ ACCORDING TO WAVEFORM ...
    SET SMIQ ACCORDING TO WAVEFORM ...   ON
    TRIGGER OUT MODE                     ON
(These settings are only needed once after presetting the generator and
serve for automatically adopting the trigger setting from the waveform file
generated by R&S WinIQSIM in ARB MOD. This is especially convenient
when changing between different waveforms.)

  SELECT WAVEFORM... Select name 'TDS_BS'
  STATE:           ON

```

Settings on analyzer:

```

[PRESET]
[FREQUENCY:      2020.0 MHz]
[TDS BS]
[AMPT:           REF LEVEL]
[MEAS:           POWER]
[ADAPT TO SIGNAL]
[AUTO LEVEL&TIME]
[START SLOT:     4]
[STOP SLOT:      6]

```

Measurement on analyzer: The following is displayed:

- Spectrum of the TD-SCDMA signal over slots 4 through 6
- Channel power within a 1.6 MHz bandwidth

Measurement 2: Measuring spectrum emission mask

TD-SCDMA specifications require a measurement that monitors maintenance of a spectral mask within at least ± 4.0 MHz of the TD-SCDMA carrier. To judge power emissions, the signal power is measured with a 30 kHz filter up to 2.3 MHz and with a 1 MHz filter between 2.3 and 4 MHz. The resulting curve is compared to a limit line defined in TD-SCDMA specifications.

Test setup:

- Connect the RF output of the R&S SMIQ to the RF input of the analyzer (coaxial cable with N connectors).
- Connect the external triggering of the analyzer (EXT TRIG GATE) to the R&S SMIQ trigger (TRIGOUT1 to PARADATA).

Settings on R&S SMIQ: *R&S SMIQ settings as for measurement 1.*

Settings on analyzer:

```

[PRESET]
[FREQUENCY:           2020.0 MHz]
[TDS BS]
[AMPT:                 REF LEVEL]
[MEAS:                 SEPCTRUM EM MASK]
[ADAPT TO SIGNAL]
[AUTO LEVEL&TIME]
[START SLOT:          4]
[STOP SLOT:           6]

```

Measurement on analyzer: The following is displayed:

- Spectrum of the TD-SCDMA signal over slots 4 through 6
- The limit line defined in the standard
- Statement of limit line violation (passed/failed)

Measurement 3: Measuring relative code domain power and frequency error

What follows is a measurement of the code domain power. The basic parameters of CDP measurements, which allow analysis of the signal, are changed one after another from values adapted to the measurement signal to non-adapted values to demonstrate the resulting effects.

Test setup: ➤ Connect the RF output of the R&S SMIQ to the RF input of the analyzer.

Settings on R&S SMIQ: *R&S SMIQ settings as for measurement 1.*

Settings on analyzer: **[PRESET]**
[FREQUENCY: 2020.0 MHz]
[TDS BS]
[AMPT: REF LEVEL
[SELECT SLOT: 4]

Measurement on analyzer: The following is displayed:

Screen A: Code domain power of the signal in slot 4

Screen B: Numeric results of CDP measurement including the frequency error

Setting: Synchronizing reference frequencies

Synchronizing the transmitter and receiver to the same reference frequency reduces the frequency error.

- Test setup: ➤ Connect the reference input (EXT REF IN / OUT) on the rear panel of the analyzer to the reference output (REF) on the rear of the R&S SMIQ (coaxial cable with BNC connectors).
- Settings on R&S SMIQ: *R&S SMIQ settings as for measurement 1.*
- Settings on analyzer: *As for measurement 3, plus*
[SETUP: REFERENCE EXT]
- Measurement on analyzer: Screen B: Frequency error: The indicated frequency error should be < 10 Hz.

The reference frequencies of the analyzer and device under test should be synchronized.

Setting: Response to deviating center frequency setting

The following shows the response of the DUT and analyzer to a deviating center frequency setting.

- Settings on R&S SMIQ: ➤ Detune the center frequency of the signal generator in 0.5 kHz increments and observe the analyzer screen while doing so.
- Measurement on analyzer:
 - Up to a frequency error of about 4.5 kHz a CDP measurement is still possible on the analyzer. There is no apparent difference in the accuracy of CDP measurement up to this frequency error.
 - Above 4.5 kHz frequency offset, the probability of incorrect synchronization increases. The "Sync Failed" message appears.
 - Above a frequency error of about 5 kHz, a CDP measurement becomes impossible. The "Sync Failed" message appears.
- Settings on R&S SMIQ: ➤ Reset the signal generator center frequency to 2020.0 MHz:
[FREQ: 2020.0 MHz]

The analyzer center frequency should not offset from the DUT frequency by more than 4.5 kHz.

Setting: Response to wrong scrambling code

You can only perform a valid CDP measurement if the scrambling code set on the analyzer matches that of the transmit signal.

Settings on R&S SMIQ: *R&S SMIQ settings as for measurement 1.*

Settings on analyzer: Set the scrambling code to a wrong figure:

[SETTINGS: SCRAMBLING CODE 1]

Measurement on analyzer: The "Sync Failed" message appears. In some cases a wrong scrambling code will lead to display of a valid signal but with the wrong channel occupancy!

Settings on analyzer: Set the scrambling code to the correct figure:

[SETTINGS: SCRAMBLING CODE 0]

Measurement on analyzer: The CDP display again shows the test model.

<p>The setting of the scrambling code on the analyzer must agree with that of the signal to be measured.</p>

Measurement 4: Measuring composite EVM

Composite EVM is a measurement of the mean square error of the total signal required by TD-SCDMA specifications.

An ideal reference signal is generated from the demodulated data. The test signal and reference signal are compared; the square deviation produces the composite EVM.

Test setup: ➤ Connect the RF output of the R&S SMIQ to the RF input of the analyzer (coaxial cable with N connectors).

Settings on R&S SMIQ: *R&S SMIQ settings as for measurement 1.*

Settings on analyzer:

[PRESET]	
[FREQUENCY:	<i>2020.0 MHz]</i>
[TDS BS]	
[AMPT:	<i>REF LEVEL</i>
[RESULTS	<i>COMPOSITE EVM]</i>
[SELECT SLOT:	<i>4]</i>

Measurement on analyzer: The following is displayed:

Screen A: Code domain power of the signal in slot 4

Screen B: Composite EVM (EVM for total signal)

Note: *EVM measurement serves no purpose in inactive slots. No figure is displayed.*

Measurement 5: Measuring peak code domain error

An ideal reference signal is generated from the demodulated data for peak code domain error measurement. The test signal and reference signal are compared; the difference between the two signals is projected to the class of the spreading factor 16. The peak code domain error is obtained by summing over the symbols of each slot of the difference signal and searching for the maximum error code.

Test setup: ➤ Connect the RF output of the R&S SMIQ to the RF input of the analyzer (coaxial cable with N connectors).

Settings on R&S SMIQ: *R&S SMIQ settings as for measurement 1.*

Settings on analyzer:

[PRESET]	
[FREQUENCY:	<i>2020.0 MHz]</i>
[TDS BS]	
[AMPT:	<i>REF LEVEL</i>
[RESULTS	<i>PK CODE DOM ERROR]</i>
[SELECT SLOT:	<i>4]</i>

Measurement on analyzer: The following is displayed:

Screen A: Code domain power of the signal in slot 4

Screen B: Peak code domain error (for spreading factor 16)

Note: *Peak code domain error measurement serves no purpose in inactive slots. No figure is displayed.*

Measurement 6: Measuring RHO factor

What follows is a measurement of the RHO factor.

Test setup: ➤ Connect the RF output of the R&S SMIQ to the RF input of the analyzer.

Settings on R&S SMIQ: *R&S SMIQ settings as for measurement 1.*

Settings on analyzer: **[PRESET]**
 [FREQUENCY: 2020.0 MHz]
 [TDS BS]
 [AMPT: REF LEVEL]
 [SELECT SLOT: 4]

Measurement on analyzer: The following is displayed:

Screen A: Code domain power of the signal in slot 4

Screen B: Numeric results of CDP measurement in slot 4 including the RHO factor

3 Setup for Base Station Tests



Caution:

Before putting the unit into operation, make sure that:

- The housing covers are in place and their screws have been tightened.
- Vent holes are not obstructed.
- No signal voltage levels above permissible limits are applied to the inputs.
- The outputs of the instrument are not overloaded or wrongly connected.

Any non-compliance with these precautions may cause damage to the instrument.

This chapter describes the default settings of the analyzer for operation as a TD-SCDMA base station tester. A requisite before starting is that the analyzer is correctly configured and powered, as described in Chapter 1 of the operating manual for the basic unit. Furthermore, the Application Firmware R&S FS-K76 must be enabled. Installation and enabling of the application firmware are described in Chapter 1 of this software manual.

Standard test setup

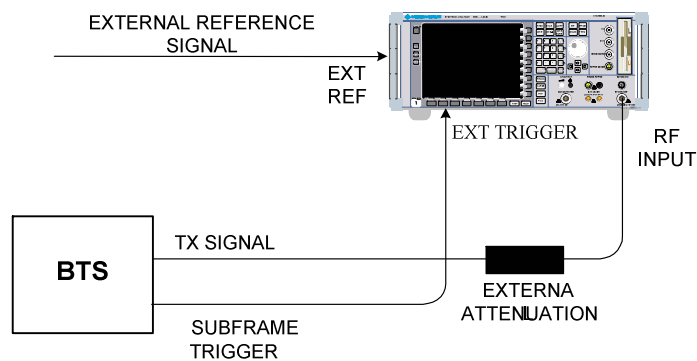

Fig. 3-1 BTS test setup

- Connect the antenna output (or TX output) of the base station to the RF input of the analyzer through a power attenuator exhibiting suitable attenuation. The following values for external attenuation are recommended to ensure that the RF input of the analyzer is protected and the unit's sensitivity is not excessively degraded:

Max. power	Recommended external attenuation
≥ 55 to 60 dBm	35 to 40 dB
≥ 50 to 55 dBm	30 to 35 dB
≥ 45 to 50 dBm	25 to 30 dB
≥ 40 to 45 dBm	20 to 25 dB
≥ 35 to 40 dBm	15 to 20 dB
≥ 30 to 35 dBm	10 to 15 dB
≥ 25 to 30 dBm	5 to 10 dB
≥ 20 to 25 dBm	0 to 5 dB
< 20 dBm	0 dB

- For signal measurements at the output of twoport networks, connect the reference frequency of the signal source to the rear reference input of the analyzer (*EXT REF IN / OUT*).
- To ensure adherence to the error limits required by TD-SCDMA specifications for frequency measurements on base stations, the analyzer must be operated on an external reference. A rubidium frequency standard is a possible reference source.
- If the base station has a trigger output, connect it to the rear trigger input of the analyzer (*EXT TRIG GATE*).

Default setting

- Enter the external attenuation. **[AMPT] [NEXT] [REF LVL OFFSET]**
- Enter the reference level. **[AMPT]**
- Enter the center frequency. **[FREQUENCY]**
- Set the trigger. **[TRIG]**
- If used, switch on the external reference. **[SETUP] [REF: EXT]**
- Select the standard and the required measurement. **[TDS BS] [RESULTS]**
- Set the scrambling code. **[SETTINGS] [SCRAMBLING CODE]**
- Set the maximum number of midambles. **[SETTINGS] [MA SHIFTS CELL]**

The *MEAS* hotkey is identical to the *MEAS* key (right on the front panel) and is used to select the different RF measurements or the code domain analyzer. Selecting the *CHAN CONF* or *RESULTS* hotkey automatically switches to the code domain analyzer. Pressing the *EXIT TDS* hotkey exits from R&S FS-K76. The hotkey bar of the basic unit appears again and the analyzer goes into the default *SPECTRUM* mode.

Change from *SPECTRUM* mode to application firmware:

The following user-specific settings are not modified, so the matching to the device under test is preserved:

- Reference Level + Ref Level Offset
- Center Frequency + Frequency Offset
- Input Attenuation + Mixer Level

The following user-specific settings are adopted as follows:

- External trigger sources are preserved, while all other trigger sources result in *FREE RUN* mode.
- Additional trigger settings are preserved.

Change from application firmware to *SPECTRUM* mode:

The following user-specific settings are not modified, so the matching to the device under test is preserved:

- Reference Level + Ref Level Offset
- Center Frequency + Frequency Offset
- Input Attenuation + Mixer Level

The following user-specific settings are adopted as follows:

- The trigger source is switched to *FREE RUN* and an analyzer frequency sweep is set with the span equal to double the center frequency, or the maximum possible span, so that in any case the center frequency remains unchanged.

The measurements available in R&S FS-K76 can be selected by the MEAS hotkey or the MEAS key:

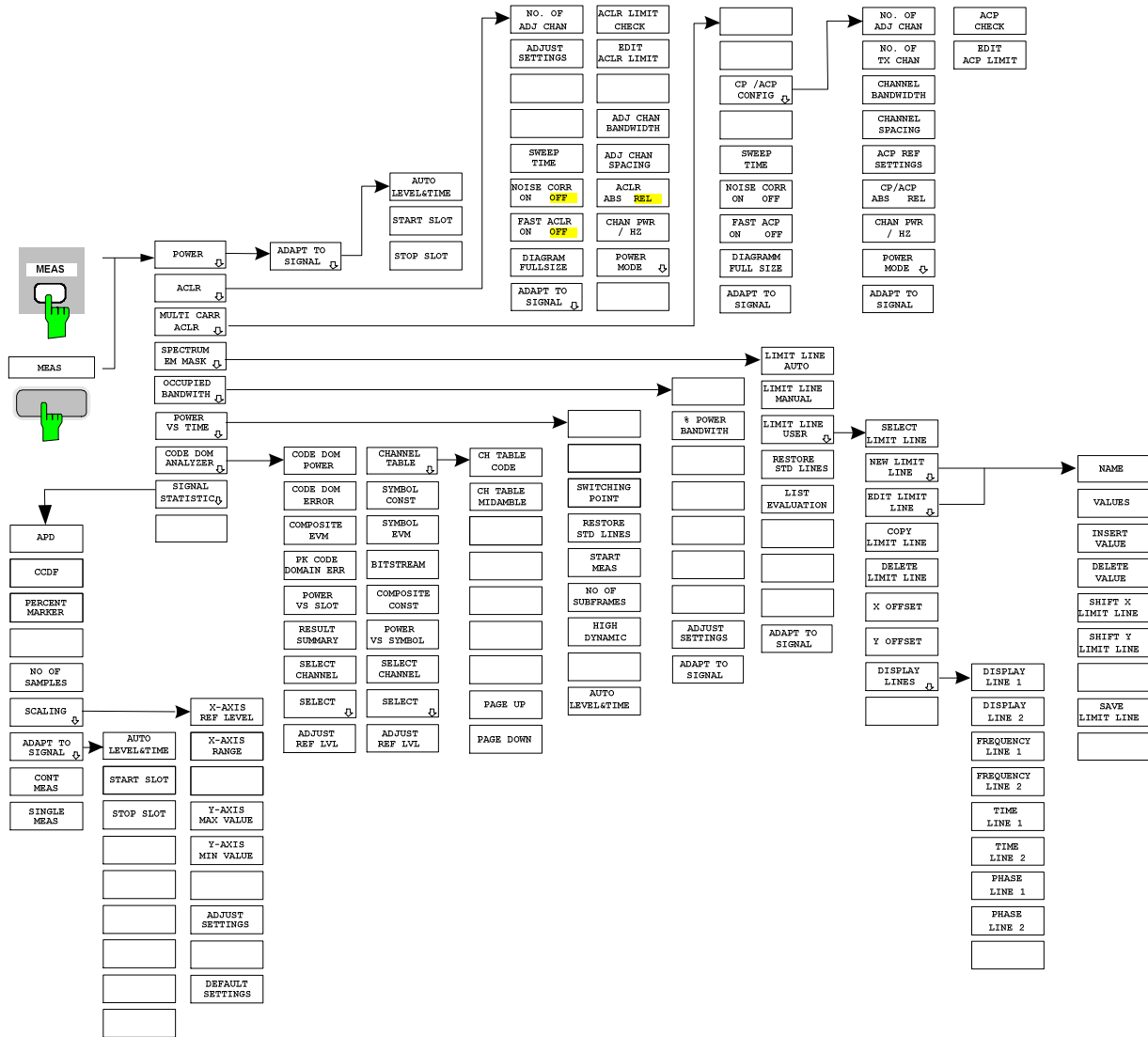

Fig. 4-3 Overview of menus

5 Configuration of TD-SCDMA Measurements

The major measurements of the TD-SCDMA specifications for base stations can be selected by the *MEAS* hotkey and the *MEAS* key. They are explained below with reference to the softkey functions.

The *CODE DOM ANALYZER* softkey activates the code domain analyzer and takes you to the submenus for selecting the results. Changing the occupancy of the hotkey bar when entering the application ensures that the major parameters of the code domain analyzer can be directly accessed on the hotkey bar.

The *POWER*, *ACLR*, *SPECTRUM EM MASK*, *OCCUPIED BANDWIDTH* and *POWER VS TIME* softkeys activate base station measurements with predefined settings that are performed in *SPECTRUM* mode of the basic unit. The measurements are performed with the parameters of the TD-SCDMA specifications. Subsequent alteration of the settings is possible.

MEAS key or *MEAS* hotkeys

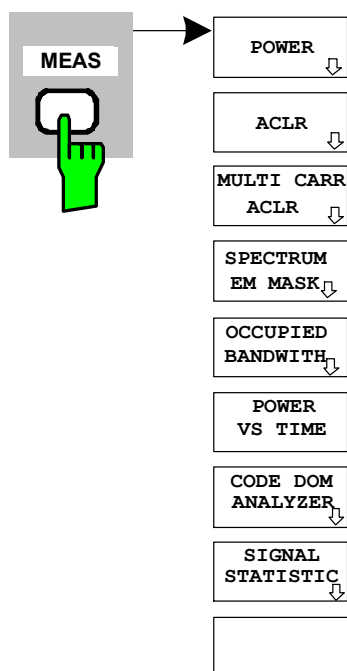

The *MEAS* hotkey or the *MEAS* key opens a submenu for selecting measurements:

- *POWER* activates channel power measurement with defined defaults in *SPECTRUM* mode.
- *ACLR* activates adjacent channel power measurement with defined defaults in *SPECTRUM* mode.
- *MULT CARR ACLR* activates measurement of the multi carrier adjacent channel power
- *SPECTRUM EM MASK* compares the signal power in different carrier offset ranges with the maximum values of the TD-SCDMA specifications.
- *OCCUPIED BANDWIDTH* activates measurement of the bandwidth occupied by the signal.
- *POWER VS TIME* activates measurement of the signal power versus time with the template of TD-SCDMA specifications.
- *CODE DOM ANALYZER* activates the code domain analyzer and opens another menu for choosing the results. All other menus of the analyzer are matched to the functions of the code domain analyzer mode. The code domain analyzer is described in a separate chapter starting on page 51.
- *SIGNAL STATISTIC* evaluates the signal with regard to its statistical characteristics (distribution function of the signal amplitudes).

Measurement of channel power

MEAS key or MEAS hotkey

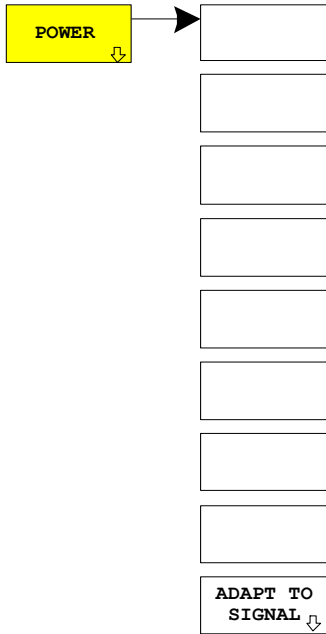

The *POWER* softkey activates measurement of channel power of the TD-SCDMA signal.

The analyzer measures the power of the RF signal over a bandwidth of 1.6 MHz in selected slots. The power is calculated by summing the values at the trace points. The bandwidth and the associated channel power are displayed below the measurement screen.

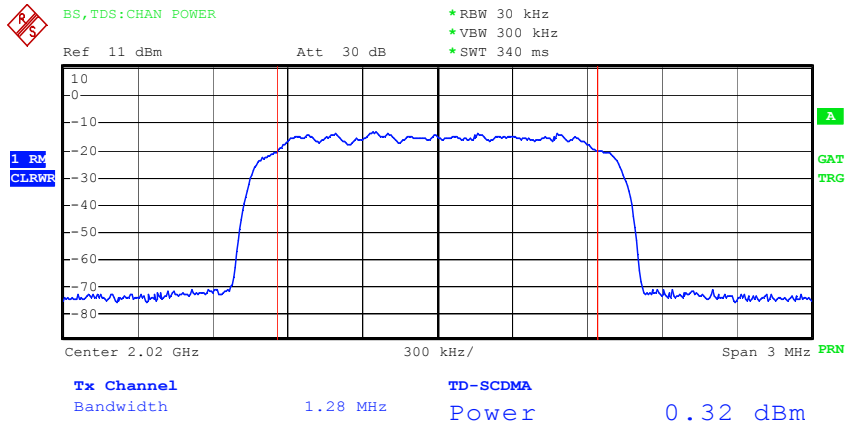

Fig. 5-1 Power measurement over 1.6 MHz bandwidth

The softkey activates *SPECTRUM* mode with defined settings:

The following user-specific settings are not modified, so the matching to the device under test is preserved:

- Reference Level + Ref Level Offset
- Center Frequency + Frequency Offset
- Input Attenuation + Mixer Level

FREQUENCY SPAN	3 MHz
TRIGGER	EXTERN

Proceeding from this setting, the analyzer can be operated with all the functionality it offers in *SPECTRUM* mode, i.e. all parameters can be matched to a specific measurement.

To restore adapted measurement parameters, the following parameters are saved on exiting and are set again on re-entering this measurement:

- Level parameters
- RBW, VBW
- Sweep time

IEC/IEEE bus command: :CONF:CDP:MEAS POW

Result poll: :CALC:MARK:FUNC:POW:RES? CPOW



The *ADAPT TO SIGNAL* softkey opens a submenu for matching the reference level of the analyzer and configuration of the gated sweep mode.

The reference level of the analyzer is matched to the measured channel power. This ensures that the RF attenuation and reference level settings are optimally matched to the signal level without the analyzer being overloaded or the dynamic response limited by too low a signal/noise ratio.

The measurement bandwidth for channel power measurements is considerably less than the signal bandwidth, so the signal path may be overloaded although the trace is still well below the reference level.

Power measurements are only possible in gated sweep mode because the TD-SCDMA signal is slot-based. So the trigger/subframe relationship must be created and the slots set that are to be analyzed. Analysis is possible over contiguous slots 1 through 7. Slot 7 corresponds to slot 0 of the following subframe. In TD-SCDMA specifications, analysis is over slots 4, 5 and 6. An external trigger signal must be applied.

The guard period of the stop slot is excluded from the measurement. The sweep time is adapted to the gate length, so that for every sweep point all selected slots are taken into account.



The *AUTO LEVEL & TIME* softkey starts the autorange routine for the reference level. This also creates the relationship between trigger and subframe start.

IEC/IEEE bus command: `:SENS:POW:ACH:AUTO:LTIM`

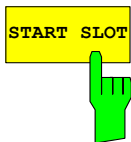

The *START SLOT* softkey allows entry of the start slot for gated sweep mode. The gated mode is on between START SLOT and STOP SLOT. For the remaining slots of a subframe the gated mode is off.

IEC/IEEE bus command: `:SENS:POW:ACH:SLOT:START 1...7`

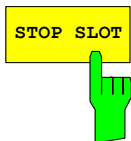

The *STOP SLOT* softkey allows entry of the stop slot for gated sweep mode. The gated mode is on between START SLOT and STOP SLOT. For the remaining slots of a subframe the gated mode is off.

IEC/IEEE bus command: `:SENS:POW:ACH:SLOT:STOP 1...7`

Measurement of adjacent channel power – ACLR

MEAS key or MEAS hotkey

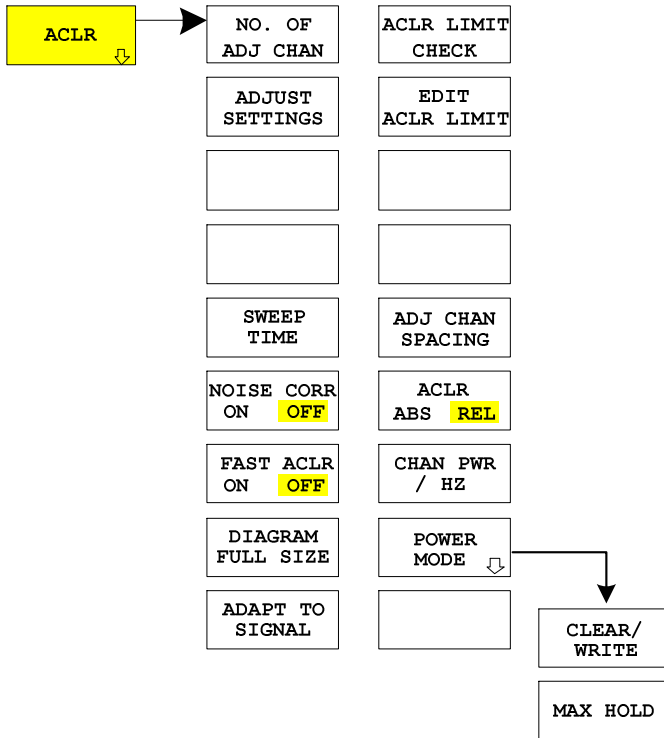

The ACLR (adjacent channel leakage power ratio) softkey activates measurement of adjacent channel power. Settings and limits are taken from the ACLR measurement defined in TD-SCDMA specifications.

The analyzer measures the power of the useful channel and of the adjacent left and right channels in selected slots. In the default setting, only two adjacent channels are considered. Measurement results are displayed below the measurement screen.

The ACLR limit check can be enabled or disabled by the *ACLR LIMIT CHECK* softkey.

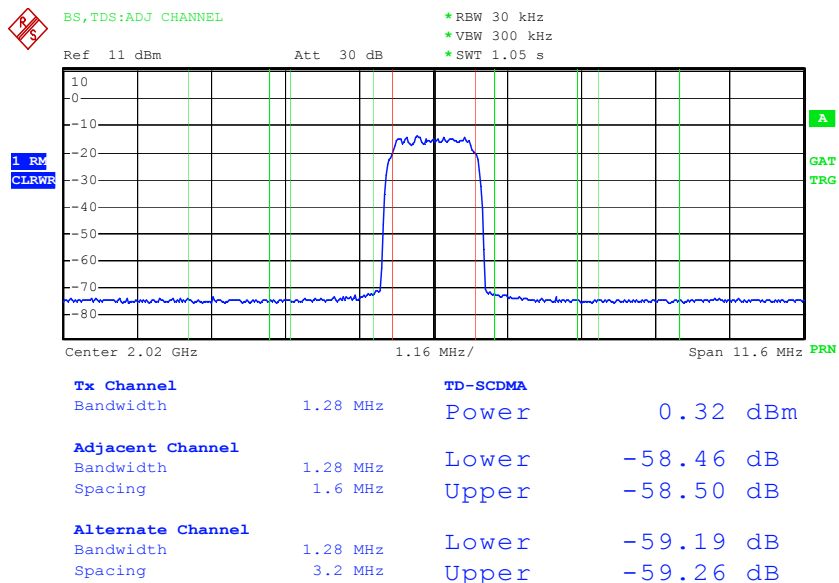

Fig. 5-2 Measuring adjacent channel power

The softkey activates *SPECTRUM* mode with defined settings:

The following user-specific settings are not modified, so the matching to the device under test is preserved: Reference Level + Ref Level Offset Center Frequency + Frequency Offset Input Attenuation + Mixer Level	
ADJACENT CHAN POWER	ON
ACP STANDARD	TD-SCDMA
NO OF ADJ CHANNELS	2
TRIGGER	EXTERN
EXT GATE	ON

Table 5-1 Default ACLR settings

Adjacent channel type	Spacing	RBW	Abs. Limit
Adjacent	±1.6 MHz	30 kHz	-15.2 dBm
Alternate	±3.2 MHz	30 kHz	-15.2 dBm

Proceeding from this setting, the analyzer can be operated in all the functions it features in *SPECTRUM* mode, i.e. all measurement parameters can be matched to the specific measurement.

To restore adapted measurement parameters, the following parameters are saved on exiting and are set again on <u>re-entering</u> this measurement: Level parameters RBW, VBW Sweep time SPAN NO OF ADJ. CHANNELS FAST ACLR MODUS	
--	--

IEC/IEEE bus command: :CONF:CDP:MEAS ACLR

Result poll: :CALC:MARK:FUNC:POW:RES? ACP

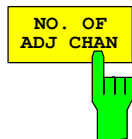

The *NO. OF ADJ CHAN* softkey activates entry of the number ±n of adjacent channels that are taken into account for the adjacent channel power measurement.

A number between 0 and 12 can be entered.

The following measurements are performed depending on the number of channels.

- 0 Only the channel power is measured.
- 1 The channel power and the power of the upper and lower adjacent channel are measured.
- 2 The channel power, the power of the upper and lower adjacent channel and of the next upper and lower channel (alternate channel 1) are measured.
- 3 The channel power, the power of the upper and lower adjacent channel and of the next two upper and two lower channels (alternate channel 1 and alternate channel 2) are measured.

With higher numbers the procedure is expanded accordingly.

IEC/IEEE bus command: :SENS:POW:ACH:ACP 2

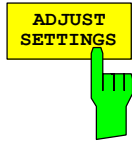

All analyzer settings relevant for power measurement within a specific frequency band (channel bandwidth) are optimally set as a function of channel configuration (channel bandwidth, channel spacing):

- Frequency span:
The frequency span must at least cover all channels to be considered. When channel power is measured, the span is set to double the channel bandwidth.
The setting of the span for adjacent channel power measurement depends on the channel spacing and channel bandwidth of the adjacent channel ADJ, ALT1 or ALT2 furthest from the transmission channel.
- Resolution bandwidth $RBW \leq 1/40$ of channel bandwidth
- Video bandwidth $VBW \geq 3 \times RBW$
- Detector RMS detector

The trace math and trace averaging functions are switched off. The reference level is not influenced by *ADJUST SETTINGS*. It can be separately adjusted with *AUTO LEVEL&TIME*.

Adjustment is performed once; if necessary, the unit settings can be modified afterwards.

IEC/IEEE bus command:

```
:SENS:POW:ACH:PRES ACP|CPOW|OBW
```

For manual setting of the measurement parameters differing from the settings made with *ADJUST SETTINGS*, the following must be taken into account for the different parameters:

Frequency span	The frequency span must at least cover all channels to be measured. This is the channel bandwidth when channel power is measured. If the frequency span is large compared with the analyzed frequency section (or frequency sections), only a few points on the trace are available for the measurement.
Resolution bandwidth (RBW)	To ensure an acceptable measurement speed and also the necessary selectivity (to reject spectral components outside the channel you want to measure, especially the adjacent channels), the resolution bandwidth must be neither too small nor too large. As a rule of thumb, the resolution bandwidth should be set to between 1 and 4% of the channel bandwidth. A larger resolution bandwidth can be set if the spectrum within and around the channel you want to measure has a flat characteristic.
Video bandwidth (VBW)	For a correct power measurement, the video signal must not be limited in terms of bandwidth. A restricted band of the logarithmic video signal would result in averaging and thus in too small an indication of the power (–2.51 dB for very small video bandwidths). So the video bandwidth should be at least three times the resolution bandwidth. The <i>ADJUST SETTINGS</i> softkey sets the video bandwidth (VBW) as a function of the channel bandwidth as follows: $VBW \geq 3 \times RBW$
Detector	The <i>ADJUST SETTINGS</i> softkey selects the RMS detector. The RMS detector is selected because it always indicates the power correctly irrespective of the characteristics of the signal you want to measure. In principle, even the sample detector would be possible. However, this would lead to more unstable results due to the limited number of trace pixels for calculating the power in the channel. Averaging, frequently performed to stabilize measurement results, leads to the level indication being too low and should therefore be avoided. The reduction in the displayed power depends on the number of averages and the signal characteristics in the channel you want to measure.



The *SWEEP TIME* softkey activates entry of the sweep time. When the RMS detector is used, a longer sweep time yields more stable results. This setting is identical to the *SWEEP TIME MANUAL* setting in the *BW* menu.

IEC/IEEE bus command: : *SWE:TIME* <value>

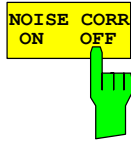

If the *NOISE CORR ON / OFF* softkey is activated, the results are corrected by the instrument's own inherent noise, which increases the dynamic range.

When the function is switched on, a reference measurement of the instrument's inherent noise is first made. The measured noise power is then subtracted from the power in the channel examined. The inherent noise of the instrument depends on the selected center frequency, resolution bandwidth and level setting. So correction is disabled whenever one of these parameters is changed, and an appropriate message appears on the screen. To reactivate correction of the inherent noise with the changed setting, press the softkey once more. A new reference measurement is then made.

The function can be switched on with trigger *FREE RUN* or *EXTERN*. Then it is possible to change the trigger to an arbitrary mode.

IEC/IEEE bus command: : *SENS:POW:NCOR ON*

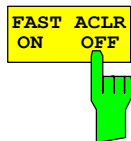

The *FAST ACLR ON / OFF* softkey toggles between measurement by the *IBW* method (*FAST ACLR OFF*) and measurement in the time domain (*FAST ACLR ON*).

For *FAST ACLR ON* the power is measured in the various channels in the time domain. The analyzer sets its center frequency in succession to the different channel center frequencies and measures the power with the set measuring time (i.e. sweep time/number of measured channels). The RBW filters suitable for the selected standard and frequency offset are used automatically.

The RMS detector is used for correct power measurement. Software correction factors are not required in this case.

Measured values are output in the form of a table, the power of the useful channel being specified in dBm and the power of the adjacent channels in dBm (*ACLR ABS*) or dB (*ACLR REL*).

The selected sweep time (= measurement time) depends on the desired reproducibility of measurement results. The longer the selected sweep time, the better the reproducibility of results, because power is measured over a longer period of time.

As a rule of thumb it can be assumed that approx. 500 uncorrelated values are required for reproducibility of 0.5 dB, i.e. 99% of measurements are within 0.5 dB of the true measured value (applies to white noise). Measured values are considered uncorrelated if their time spacing corresponds to the reciprocal of the measurement bandwidth (1/BW).

IEC/IEEE bus command: : *SENS:POW:HSP ON*

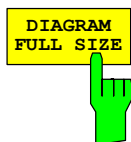

The *DIAGRAM FULL SIZE* softkey switches the diagram to full screen size.

IEC/IEEE bus command: : *DISP:WIND1:SIZE LARG*
 : *DISP:WIND1:SIZE SMAL*



The *ADAPT TO SIGNAL* softkey opens a submenu for matching the reference level of the analyzer and configuration of gated sweep mode.

The *AUTO LEVEL & TIME* softkey starts the autorange routine for the reference level. This also creates the relationship between trigger and subframe start.

The *START SLOT* softkey allows entry of the start slot for gated sweep mode. The gated mode is on between *START SLOT* and *STOP SLOT*. For the remaining slots of a subframe the gated mode is off.

The *STOP SLOT* softkey allows entry of the stop slot for gated sweep mode. The gated mode is on between *START SLOT* and *STOP SLOT*. For the remaining slots of a subframe the gated mode is off.

IEC/IEEE bus command:

```
:SENS:POW:ACH:AUTO:LTIM
:SENS:POW:ACH:SLOT:START 1...7
:SENS:POW:ACH:SLOT:STOP 1...7
```



The *ACLR LIMIT CHECK* softkey switches the limit check for the ACLR measurement on or off.

IEC/IEEE bus command:

```
:CALC:LIM:ACP ON
:CALC:LIM:ACP:ACH:RES?
:CALC:LIM:ACP:ALT1..11:RES?
```



The default setting of the limits when starting adjacent channel power measurement is defined as in the table on page 31. A table can be opened in ACLR measurement by the *EDIT ACLR LIMIT* softkey in which limits for ACLR measurement can be modified..

ACP LIMITS				
CHAN	RELATIVE LIMIT CHECK		ABSOLUTE LIMIT CHECK	
	VALUE	ON	VALUE	ON
ADJ	0 dBc		-15.2 dBm	√
ALT1	0 dBc		-15.2 dBm	√
ALT2	0 dBc		0 dBm	

The following rules apply for limit values:

- A limit value can be defined for each of the adjacent channels. The limit value applies to both the upper and lower adjacent channel.
- A relative limit and/or an absolute limit can be defined. The check can be activated separately for the two limit values.
- Compliance with active limit values is checked irrespective of whether absolute or relative limits are specified or whether the measurement itself is performed with absolute levels or a relative level ratio. If the two checks are active and the higher of the two levels is exceeded, the respective value will be marked.

Note: *Measured values violating the limit are printed red and preceded by an asterisk..*

IEC/IEEE bus command:

```
:CALC:LIM:ACP ON
:CALC:LIM:ACP:ACH 0dB,0dB
:CALC:LIM:ACP:ACH:STAT ON
:CALC:LIM:ACP:ACH:ABS -10dBm,-10dBm
:CALC:LIM:ACP:ACH:ABS:STAT ON
:CALC:LIM:ACP:ALT1 0dB,0dB
:CALC:LIM:ACP:ALT1:STAT ON
```

```
:CALC:LIM:ACP:ALT1:ABS -10dBm,-10dBm
:CALC:LIM:ACP:ALT1:ABS:STAT ON
:CALC:LIM:ACP:ALT2..11 0dB,0dB
:CALC:LIM:ACP:ALT2..11:STAT ON
:CALC:LIM:ACP:ALT2..11:ABS -10dBm,-10dBm
:CALC:LIM:ACP:ALT2..11:ABS:STAT ON
```

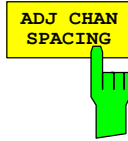

The *ADJ CHAN SPACING* softkey opens a table for defining the channel spacings.

CHANNEL SPACING	
CHAN	SPACING
ADJ	1.6 MHz
ALT1	3.2 MHz
ALT2	4.8 MHz

Adjacent channels frequently have identical spacings, so entering the adjacent channel spacing ADJ sets channel ALT1 to twice and channel ALT2 to three times the channel spacing of the adjacent channel. This means that only one value has to be entered when channel spacings are identical. The same applies to the ALT2 channel when entering the spacing of the ALT1 channel.

Note: Channel spacings can be set independently of each other by overwriting the table from top to bottom.

```
IEC/IEEE bus command: :SENS:POW:ACH:SPAC:ACH 1.6MHz
:SENS:POW:ACH:SPAC:ALT1 3.2MHz
:SENS:POW:ACH:SPAC:ALT2..11 4.8MHz
```

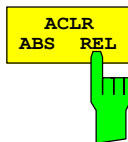

The *ACLR ABS / REL* softkey toggles between absolute and relative measurement of the channel power.

ACLR ABS The absolute value of the power in the transmission channel and the adjacent channels is displayed in the units of the Y axis, e.g. dBm, dBμV.

ACLR REL In adjacent channel power measurement (*NO. OF ADJ CHAN > 0*), the level of the adjacent channels is displayed relative to the level of the transmission channel in dBc.

With linear scaling of the Y axis, the relative power (CP/CP_{ref}) of the new channel to the reference channel is displayed. With dB scaling, the logarithmic ratio $10 \cdot \lg(CP/CP_{ref})$ is displayed. This means that the relative channel power measurement can also be used for general adjacent channel power measurements. Each channel is measured separately in this latter instance.

```
IEC/IEEE bus command: :SENS:POW:ACH:MODE ABS
```

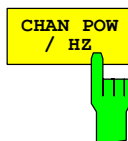

The *CHAN POW / HZ* softkey toggles between measurement of the total power in the channel and power measurement referred to 1 Hz bandwidth.

The conversion factor is $10 \cdot \lg \frac{1}{\text{Channel} \cdot \text{Bandwidth}}$.

```
IEC/IEEE bus command: :CALC:MARK:FUNC:POW:RES:PHZ ON|OFF
```

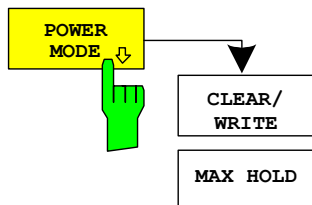

The *POWER MODE* sub menu allows to change between the normal (*CLEAR/WRITE*) and the max hold power mode. In the *CLEAR/WRITE* the channel power and the adjacent channel powers are calculated directly from the current trace. In *MAX HOLD* mode the power values are still derived from the current trace, but they are compared with a maximum algorithm to the previous power value. The greater value is remained.

```
IEC-bus command: :CALC:MARK:FUNC:POW:MODE WRIT|MAXH
```

Menu MEAS – MULT CARR ACLR

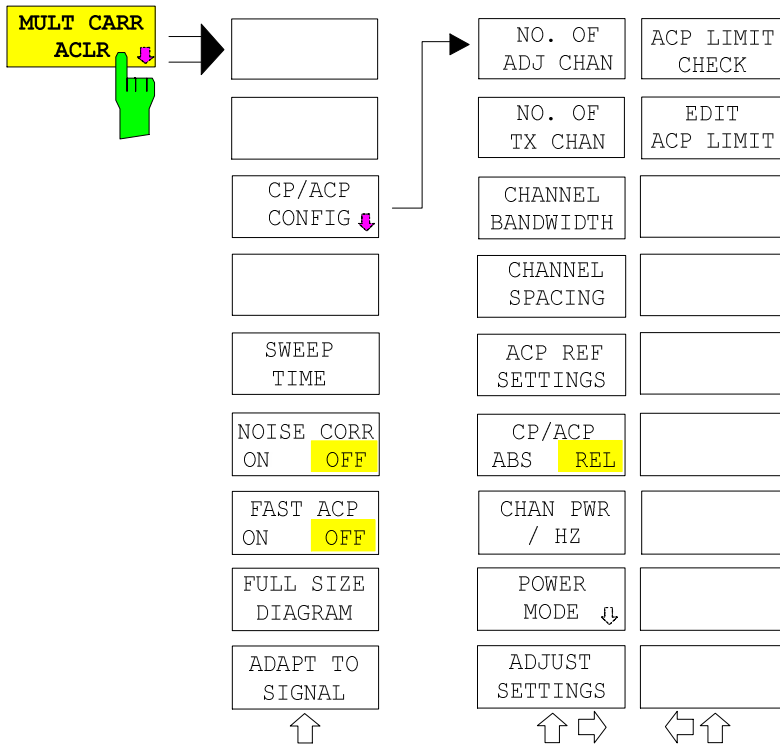

The *MULT CARR ACLR* (Multi Carrier Adjacent Channel Leakage Power Ratio) softkey enables measurement of the multi carrier adjacent channel power.

The analyzer measures the power of the 4 useful channels and of the adjacent channels on the left and right sides. In the default setting, only two adjacent channels are taken into account. Measurement results are displayed beneath the measurement screen.

The ACLR limit check can be enabled or disabled by means of the *ACLR LIMIT CHECK* softkey.

IEC/IEEE bus command: :CONF:CDP:MEAS MCAC

Query of results: :CALC:MARK:FUNC:POWER:RES? MCAC

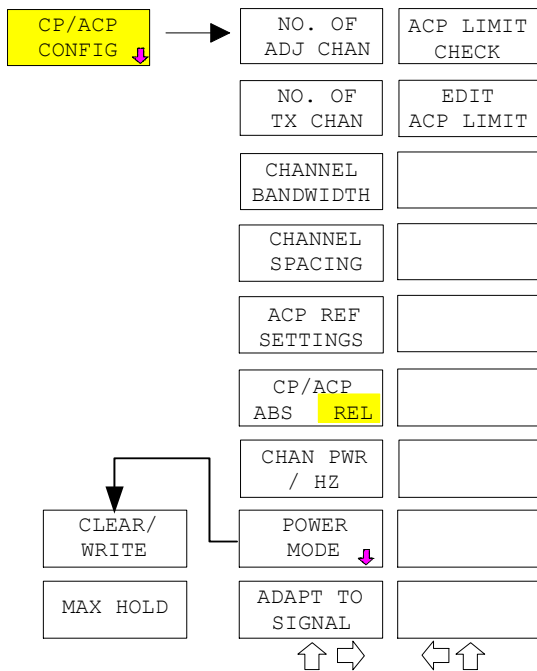

The *CP/ACP CONFIG* softkey opens a submenu for configuration of the multi carrier adjacent channel power measurement.

The channel configuration includes the number of channels to be measured, the channel bandwidths (*CHANNEL BANDWIDTH*), and the channel spacings (*CHANNEL SPACING*).

Limit values can additionally be specified for the adjacent-channel power (*ACP LIMIT CHECK* and *EDIT ACP LIMITS*) which are checked for compliance during the measurement.



This softkey behaves as in the adjacent channel power measurement – ACLR. Refer there.



The *NO. OF TX CHAN* softkey enables the entry of the number of carrier signals to be considered.

Numbers from 1 to 12 can be entered.

IEC/IEEE bus command: :SENS:POW:ACH:TXCH:COUN 4

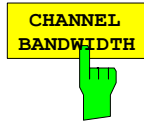

The *CHANNEL BANDWIDTH* softkey opens a table for defining the channel bandwidths for the transmission channels and the adjacent channels.

IEC/IEEE bus command: :SENS:POW:ACH:BWID:CHAN 1.28MHz
 :SENS:POW:ACH:BWID:ACH 1.28MHz
 :SENS:POW:ACH:BWID:ALT1..11 1.28MHz



The *CHANNEL SPACING* softkey opens a table for defining the channel spacings of the TX channel and the adjacent channels.

Note: *The channel spacing can be set separately by overwriting the table from top to bottom.*

IEC/IEEE bus command: :SENS:POW:ACH:SPAC:CHAN 1.6MHz
 :SENS:POW:ACH:SPAC:ACH 1.6MHz
 :SENS:POW:ACH:SPAC:ALT1 1.6MHz
 :SENS:POW:ACH:SPAC:ALT2 2.3MHz



The *ACP REF SETTINGS* softkey opens a table for selecting the transmission channel to which the adjacent-channel relative power values should be referenced.

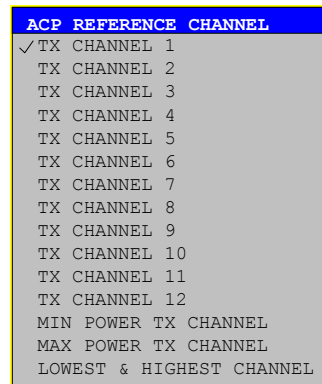

- TX CHANNEL 1 – 12** Selection of one of channels 1 to 12.
- MIN POWER TX CHANNEL** The transmission channel with the lowest power is used as a reference channel.
- MAX POWER TX CHANNEL** The transmission channel with the highest power is used as a reference channel.
- LOWEST & HIGHEST CHANNEL** The outer left-hand transmission channel is the reference channel for the lower adjacent channels, the outer right-hand transmission channel that for the upper adjacent channels.

IEC/IEEE bus command: :SENS:POW:ACH:REF:TXCH:MAN1
 :SENS:POW:ACH:REF:TXCH:AUTO MIN
 :SENS:POW:ACH:REF:TXCH:AUTO MAX
 :SENS:POW:ACH:REF:TXCH:AUTO LHIG



The *CP/ACP ABS/REL* softkey (channel power absolute/relative) switches between absolute and relative power measurement in the adjacent channels.

IEC/IEEE bus command: `:SENS:POW:ACH:MODE ABS`

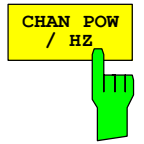

This softkey behaves as in the adjacent channel power measurement – ACLR. Refer there.

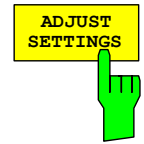

The *ADJUST SETTINGS* softkey automatically optimizes the instrument settings for the selected power measurement (see below). All instrument settings relevant for a power measurement within a specific frequency range (channel bandwidth) are optimized for the selected channel configuration (channel bandwidth, channel spacing).

IEC/IEEE bus command: `:SENS:POW:ACH:PRES MCAC`



This softkey behaves as the *ACLR LIMIT CHECK* softkey in the adjacent channel power measurement – ACLR. Refer there.



This softkey behaves as in the *EDIT ACLR LIMIT* softkey in the adjacent channel power measurement – ACLR. Refer there.



The function of the softkey is identical to the softkey *SWEEP TIME MANUAL* in the menu *BW*.

IEC/IEEE bus command: `:SENS:SWE:TIM <value>`

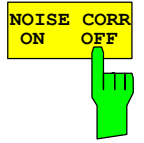

This softkey behaves as in the adjacent channel power measurement – ACLR. Refer there.



This softkey behaves as in the adjacent channel power measurement – ACLR. Refer there.

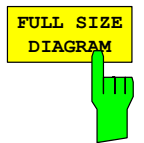

This softkey behaves as in the adjacent channel power measurement – ACLR. Refer there.

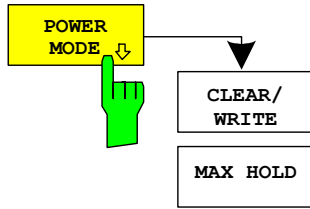

The *POWER MODE* sub menu allows to change between the normal (*CLEAR/WRITE*) and the max hold power mode. In the *CLEAR/WRITE* mode the channel power and the adjacent channel powers are calculated directly from the current trace. In *MAX HOLD* mode the power values are still derived from the current trace, but they are compared with a maximum algorithm to the previous power value. The greater value is remained.

IEC/IEEE bus command: `:CALC:MARK:FUNC:POW:MODE WRIT|MAXH`

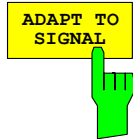

This softkey behaves as in the adjacent channel power measurement – ACLR. Refer there.

Checking signal power – SPECTRUM EM MASK

MEAS key or MEAS hotkey

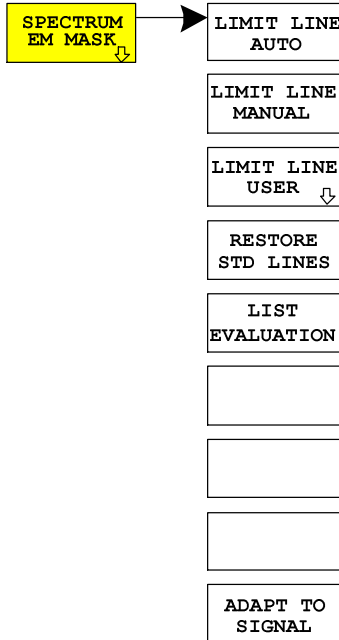

The *SPECTRUM EM MASK* (spectrum emission mask) softkey starts determination of the power of selected slots of the TD-SCDMA signal at defined offsets from the carrier and compares the power with the spectrum emission mask of TD-SCDMA specifications in the near-carrier range from -4 MHz to 4 MHz.

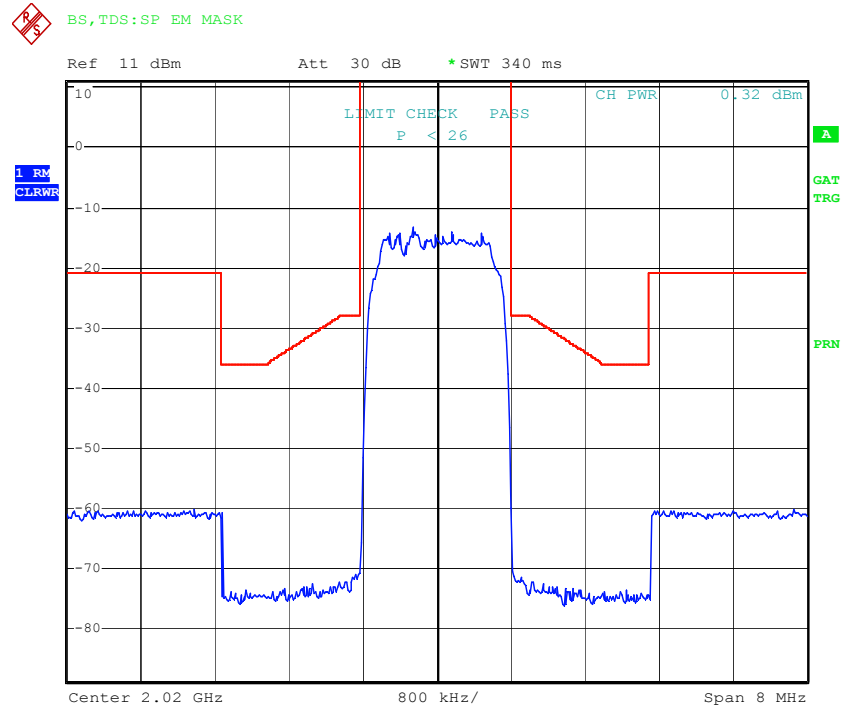

Fig. 5-3 Measurement of spectrum emission mask (3GPP)

The softkey activates spectrum mode with defined settings:

The following user-specific settings are not modified, so the matching to the device under test is preserved:

- Reference Level + Rev Level Offset
- Center Frequency + Frequency Offset
- Input Attenuation + Mixer Level

ADJACENT CHAN POWER	ON
ACP STANDARD	TD-SCDMA
NO. OF ADJ. CHANNELS	0
FREQUENCY SPAN	8 MHz
DETECTOR	RMS
TRIGGER	EXTERN

Proceeding from these settings, the analyzer can be operated in many functions featured in *SPECTRUM* mode. Changing of the RBW and VBW is limited because they are set by the definition of the limits.

To restore adapted measurement parameters, the following parameters are saved on exiting and are set again on re-entering this measurement:

- Level parameters
- Sweep time
- SPAN

IEC/IEEE bus command: :CONF:CDP:MEAS ESP

Result polls: :CALC:LIMit:FAIL?

```

:CALC1MARK1:FUNC:POW:RES? CPOW
Query of results of worst fail: :CALC:LIM:ESP:CHECK:X?
                               :CALC:LIM:ESP:CHECK:Y?
    
```

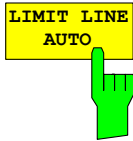

The *LIMIT LINE AUTO* softkey automatically selects the limit line after the power in the useful channel has been determined. If the measurement is performed in a *CONTINUOUS SWEEP* and the channel power varies from sweep to sweep, this can result in continuous replotting of the limit line.

The softkey is activated when you enter spectrum emission mask measurement in 3GPP standard.

IEC/IEEE bus command: `:CALC:LIM:ESP:MODE AUTO`

Note: *If the standard TSM is selected (see softkey STANDARD in the SETTINGS menu) this softkey is not available. The limit lines have to be selected manual.*

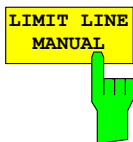

The *LIMIT LINE MANUAL* softkey enables you to select the limit line manually. If you press this softkey, the channel power measurement is not used to select the limit line but only to determine its relative components. The power at the different frequency offsets is compared with the limit line you have specified.

The softkey opens a table with all predefined limit lines on the unit:

Standard: 3GPP	Standard: TSM
limit line name	limit line name
P >= 34 dBm	P >= 43 dBm
26 dBm <= P < 34 dBm	39 <= P < 43 dBm
P < 26 dBm	31 <= P < 39 dBm
	P < 31 dBm

The name of the limit line specifies the expected power range for which the limit line was defined.

IEC/IEEE bus command: `:CALC:LIM:ESP:MODE MANual`
`:CALC:LIM:ESP:VALue 26`
`'select line 26 dBm <= P < 34 dBm`

The definition of the limit line names is described under the *LIMIT LINE USER* softkey. The spectrum emission mask limits differ between the standards 3GPP and TSM (see Softkey *STANDARD* in the *SETTINGS* menu).

3GPP standard: Spectrum Emission Mask

Table 5–2 Maximum output power $P < 26$ dBm

Offset frequency	Limit	Type/name TDSBCA.LIM	RBW
0.815 MHz – 1.015 MHz	-28 dBm	Absolute	30 kHz
1.015 MHz – 1.815 MHz	$-28dBm - 10 \cdot \left(\frac{f - f_c}{MHz} - 1,015 \right) dB$	Absolute	30 kHz
1.815 MHz – 2.3 MHz	-36 dBm	Absolute	30 kHz
2.3 MHz – Max	-21 dBm	Absolute	1 MHz

Table 5–3 Maximum output power 26 dBm $\leq P < 34$ dBm

Offset frequency	Limit	Type/name TDSBBA.LIM	RBW
0.815 MHz – 1.015 MHz	$P - 54$ dB	Relative	30 kHz
1.015 MHz – 1.815 MHz	$P - 54dB - 10 \cdot \left(\frac{f - f_c}{MHz} - 1,015 \right) dB$	Relative	30 kHz
1.815 MHz – 2.3 MHz	$P - 62$ dB	Relative	30 kHz
2.3 MHz – Max	$P - 47$ dB	Relative	1 MHz

Table 5–4 Maximum Output power $P \geq 34$ dBm

Offset frequency	Limit	Type/name TDSBAA.LIM	RBW
0.815 MHz – 1.015 MHz	-20 dBm	Absolute	30 kHz
1.015 MHz – 1.815 MHz	$-20dBm - 10 \cdot \left(\frac{f - f_c}{MHz} - 1,015 \right) dB$	Absolute	30 kHz
1.815 MHz – 2.3 MHz	-28 dBm	Absolute	30 kHz
2.3 MHz – Max	-13 dBm	Absolute	1 MHz

Changeover of the RBW is necessary in this instance. The 1 MHz channel filter is used for the 1 MHz segments.

TSM standard: Spectrum Emission MaskTabelle 5-5 Maximum output power $P < 31$ dBm

Offset frequency	Limit	Type/name TDSBTDA.LIM	RBW
0.815 MHz – 1.015 MHz	-22 dBm	Absolut	30 kHz
1.015 MHz – 1.815 MHz	$-22 - 15 \cdot (f_{\text{offset}} - 1.015)$ dBm	Absolut	30 kHz
1.815 MHz – 2.415 MHz	-36 dBm	Absolut	30 kHz
2.415 MHz – 2.9 MHz	-40 dBm	Absolut	30 kHz
2.9 MHz – Max	-25 dBm	Absolut	1 MHz

Tabelle 5-6 Maximum output power 31 dBm $\leq P < 39$ dBm

Offset frequency	Limit	Type/name TDSBTCR.LIM	RBW
0.815 MHz – 1.015 MHz	$P - 53$ dBm	Relativ	30 kHz
1.015 MHz – 1.815 MHz	$P - 53 - 15 \cdot (f_{\text{offset}} - 1.015)$ dBm	Relativ	30 kHz
1.815 MHz – 2.415 MHz	$P - 67$ dBm	Relativ	30 kHz
2.415 MHz – 2.9 MHz	$P - 71$ dBm	Relativ	30 kHz
2.9 MHz – Max	$P - 56$ dBm	Relativ	1 MHz

Tabelle 5-7 Maximum output power 39 dBm $\leq P < 43$ dBm

Offset frequency	Limit	Type/name TDSBTBA.LIM TDSBTBR.LIM	RBW
0.815 MHz – 1.015 MHz	-14 dBm	Absolut	30 kHz
1.015 MHz – 1.815 MHz	$-14 - 15 \cdot (f_{\text{offset}} - 1.015)$ dBm	Absolut	30 kHz
1.815 MHz – 2.415 MHz	-28 dBm	Absolut	30 kHz
2.415 MHz – 2.9 MHz	$P - 71$ dBm	Relativ	30 kHz
2.9 MHz – Max	$P - 56$ dBm	Relativ	1 MHz

Tabelle 5-8 Maximum output power $P \geq 43$ dBm

Offset frequency	Limit	Type/name TDSBTAA.LIM	RBW
0.815 MHz – 1.015 MHz	-14 dBm	Absolut	30 kHz
1.015 MHz – 1.815 MHz	$-14 - 15 \cdot (f_{\text{offset}} - 1.015)$ dBm	Absolut	30 kHz
1.815 MHz – 2.3 MHz	-28 dBm	Absolut	30 kHz
2.3 MHz – Max	-13 dBm	Absolu	1 MHz

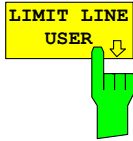

The *LIMIT LINE USER* softkey activates the entry of user-defined limit lines. The softkey opens the menus of the limit line editor, which may be familiar from the basic unit.

The following limit line settings are recommended for base station tests:

Trace 1, Domain frequency, X-scaling relative, Y-scaling absolute, Spacing linear, Unit dBm.

Unlike the default limit lines on the unit that conform to standard specifications when the analyzer is supplied, a user-specified limit line for the whole frequency range (± 4.0 MHz from the carrier) can only be either relative (to the reference level) or absolute.

The accompanying limit lines of *AUTO* and *MANUAL* modes can also be selected. The names are specified next to the type in the tables above and are defined as follows

Standard: 3GPP:

- 1) Standard in three characters
- 2) Link direction B for base station
- 3) Power class A, B, C, where A is the highest power class
- 4) Type distinction: A for absolute and R for relative

Example for TD-SCDMA and P < 26 dBm:

```
TDS      : TD-SCDMA
  B      : base station
  C      : smallest of three power classes
  A      : absolute power
=====
TDSBCA.LIM
```

Standard: TSM:

- 1) Standard in three characters
- 2) Link direction B for base station
- 3) Label for TSM standard
- 4) Power class A, B, C, where A is the highest power class
- 5) Type distinction: A for absolute and R for relative

Example for TD-SCDMA and P < 39 dBm:

```
TDS      : TD-SCDMA
  B      : base station
  C      : highest of three power classes
  A      : absolute power
=====
TDSBCA.LIM
```

The limit line names are stated in the tables next to the type.
IEC/IEEE bus command: see Table of softkeys with assignment of IEC/IEEE bus commands

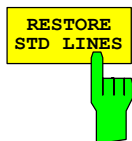

The *RESTORE STD LINES* softkey restores the limit lines defined in the standard to what they were when the unit was supplied. In this way accidental overwriting of the standard lines can be undone.

IEC/IEEE bus command: :CALC:LIM:ESP:REST



The *LIST EVALUATION* softkey reconfigures the SEM output to a split screen. In the upper half the trace with the limit line is shown. In the lower half the peak value list is shown. For every range of the spectrum emission defined by the standard the peak value is listed. For every peak value the frequency, the absolute power, the relative power to the channel power and the delta limit to the limit line is shown. As long as the delta limit is negative, the peak value is below the limit line. A positive delta indicates a failed value. The results are then colored in red, and a star is indicated at the end of the row, for indicating the fail on a black and white printout.

If the list evaluation is active, the peak list function is not available.

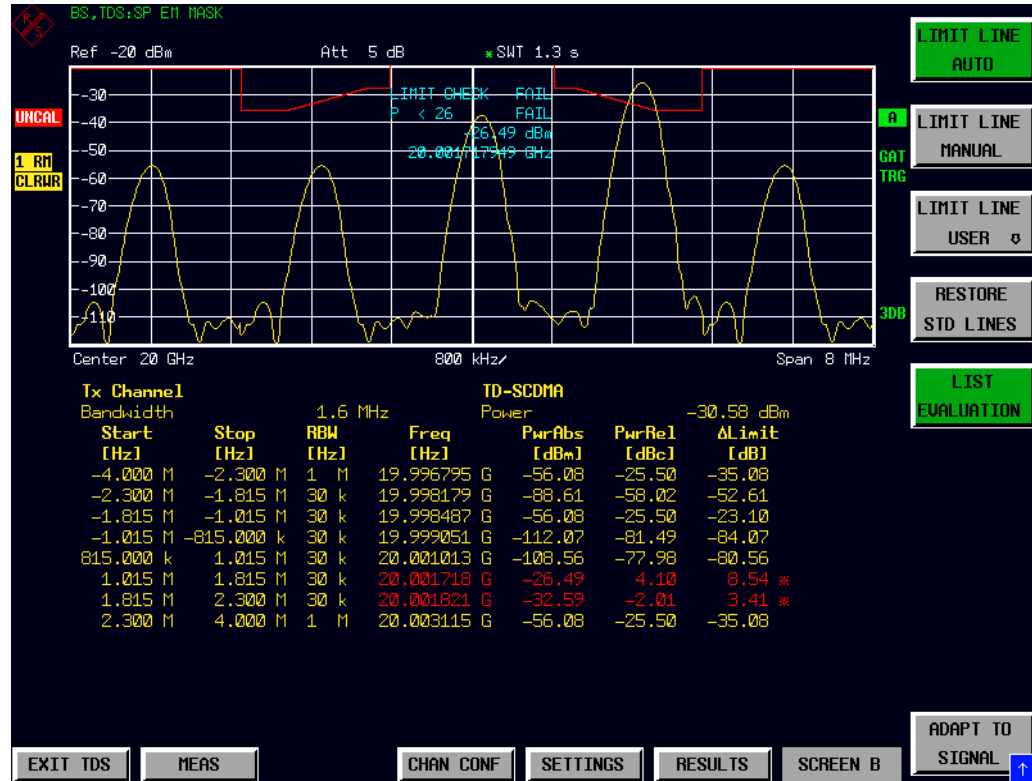

IEC/IEEE bus command: :CALC1:PEAK:AUTO ON | OFF



The *ADAPT TO SIGNAL* softkey opens a submenu for matching the reference level of the analyzer and configuration of gated sweep mode.

The *AUTO LEVEL & TIME* softkey starts the autorange routine for the reference level. This also creates the relationship between trigger and subframe start.

The *START SLOT* softkey allows entry of the start slot for gated sweep mode. The gated mode is on between *START SLOT* and *STOP SLOT*. For the remaining slots of a subframe the gated mode is off.

The *STOP SLOT* softkey allows entry of the stop slot for gated sweep mode. The gated mode is on between *START SLOT* and *STOP SLOT*. For the remaining slots of a subframe the gated mode is off.

IEC/IEEE bus commands: :SENS:POW:ACH:AUTO:LTIM
 :SENS:POW:ACH:SLOT:START 1...7
 :SENS:POW:ACH:SLOT:STOP 1...7

Measurement of bandwidth occupied by signal – OCCUPIED BANDWIDTH

MEAS key or MEAS hotkey

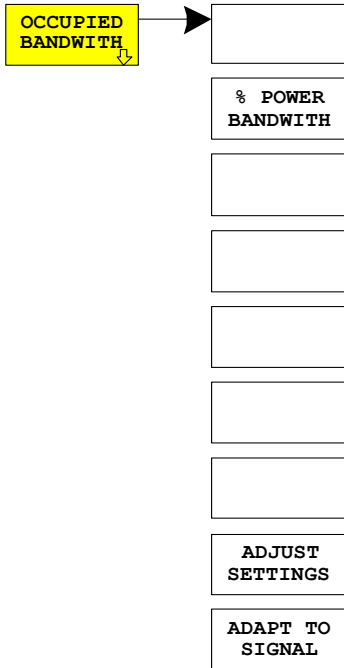

The *OCCUPIED BANDWIDTH* softkey activates measurement of the bandwidth occupied by the signal in selected slots.

This measurement determines the bandwidth in which – in the initial state – 99% of the signal power is found. The percentage signal power to be included in the bandwidth measurement can be modified. The bandwidth and the frequency markers for measurement are shown in the marker field in the top right corner of the display.

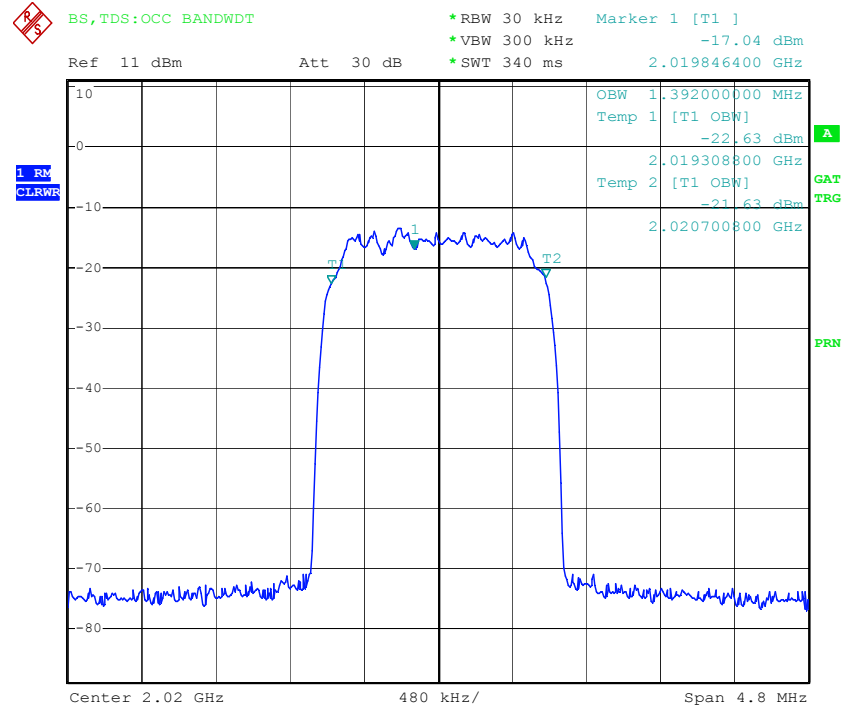

Fig. 5–4 Measuring occupied bandwidth

The softkey activates *SPECTRUM* mode with defined settings:

The following user-specific settings are not modified, so the matching to the device under test is preserved:
 Reference Level + Ref Level Offset
 Center Frequency + Frequency Offset
 Input Attenuation + Mixer Level

OCCUPIED BANDWIDTH	ON
FREQUENCY SPAN	4.8 MHz
RBW	30 kHz
VBW	300 kHz
DETECTOR	RMS
TRIGGER	EXTERN

To restore adapted measurement parameters, the following parameters are saved on exiting and are set again on re-entering this measurement:
 Level parameters
 RBW, VBW
 Sweep time
 SPAN

IEC/IEEE bus command: :CONF:CDP:MEAS OBAN

Result poll: :CALC:MARK:FUNC:POW:RES? OBAN

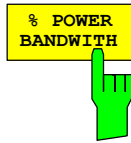

The *% POWER BANDWIDTH* softkey opens a box for entering the percentage power referred to the total power in the displayed frequency range by which the occupied bandwidth is defined (percentage of total power).
The permissible range is 10 to 99.9%.

IEC/IEEE bus command: `:SENS:POW:BWID 99PCT`

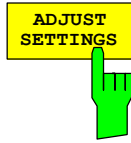

The *ADJUST SETTINGS* softkey matches the analyzer unit settings to the specified channel bandwidth for measurement of the occupied bandwidth.

All analyzer settings relevant to power measurement within a certain frequency range (channel bandwidth) such as:

- Frequency span $3 \times$ channel width

- Resolution bandwidth $RBW \leq 1/40$ of channel bandwidth
- Video bandwidth $VBW \geq 3 \times RBW$
- Detector RMS

are optimized.

The reference level is not influenced by *ADJUST SETTINGS*. It must be set for optimum dynamic range so that the maximum signal is close to the reference level.

Adjustment is performed only once but, if necessary, the unit settings may be changed afterwards.

IEC/IEEE bus command: `:SENS:POW:PRES OBW`

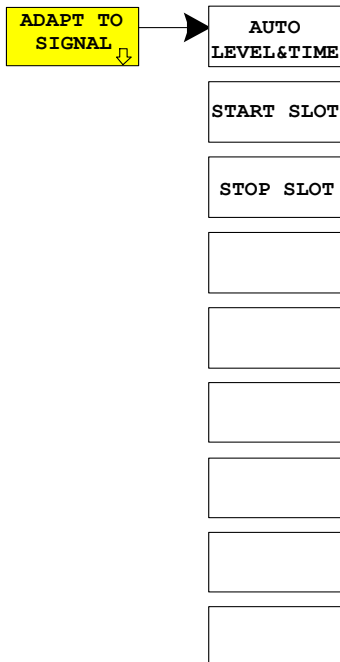

The *ADAPT TO SIGNAL* softkey opens a submenu for matching the reference level of the analyzer and configuration of gated sweep mode.

The *AUTO LEVEL & TIME* softkey starts the autorange routine for the reference level. This also creates the relationship between trigger and subframe start.

The *START SLOT* softkey allows entry of the start slot for gated sweep mode. The gated mode is on between *START SLOT* and *STOP SLOT*. For the remaining slots of a subframe the gated mode is off.

The *STOP SLOT* softkey allows entry of the stop slot for gated sweep mode. The gated mode is on between *START SLOT* and *STOP SLOT*. For the remaining slots of a subframe the gated mode is off.

IEC/IEEE bus commands: `:SENS:POW:ACH:AUTO:LTIM`
`:SENS:POW:ACH:SLOT:START 1...7`
`:SENS:POW:ACH:SLOT:STOP 1...7`

Signal power versus time – POWER VS TIME

MEAS key or MEAS hotkey

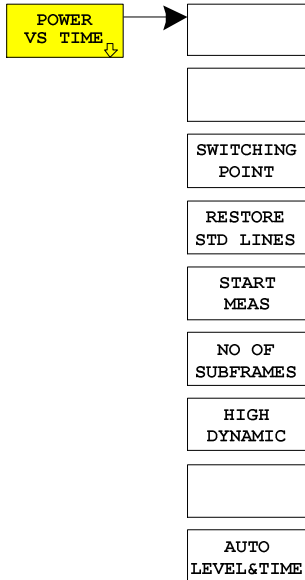

The *POWER VS TIME* softkey activates measurement of signal power versus time.

In this measurement the subframe start is determined and the signal power versus time compared with the transmit on/off template of TD-SCDMA specifications. This presents the time segment from the end of slot 0 to the switching point.

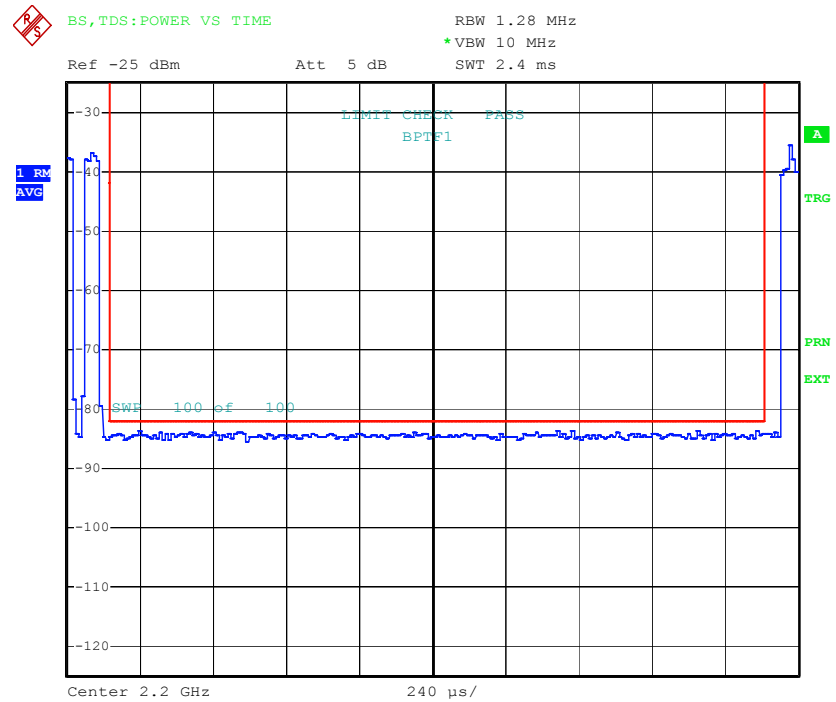

Fig. 5–5 Measuring signal power versus time

The softkey activates *SPECTRUM* mode with defined settings:

The following user-specific settings are not modified, so the matching to the device under test is preserved:
 Reference Level + Ref Level Offset
 Center Frequency + Frequency Offset
 Input Attenuation + Mixer Level

SWEEP TIME	2.4 ms
RBW	1.28 MHz RRC]
VBW	10 MHz
DETECTOR	RMS
TRIGGER	EXTERN

To restore adapted measurement parameters, the following parameters are saved on exiting and are set again on re-entering this measurement:
 Level parameters
 RBW
 Sweep time
 SPAN

IEC/IEEE bus command: :CONF:CDP:MEAS PVT

Result poll: :CALC1:LIM1:FAIL?

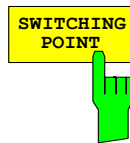

The *SWITCHING POINT* softkey opens an entry box for the number of the last slot in the Off Power time. The switching point defines the boundary between uplink and downlink slots.

IEC/IEEE bus command: `:CONF:CDPower:PVT:SPO 1...6`

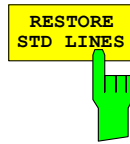

The *RESTORE STD LINES* softkey restores the limit lines defined in the standard to what they were when the unit was supplied. In this way accidental overwriting of the standard lines can be undone.

IEC/IEEE bus command: `:CALC:LIM:PVT:REST`

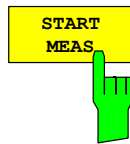

Der Softkey *START MEAS* starts a single sweep measurement.

IEC/IEEE bus command: `:INIT:CONT OFF;:INIT`

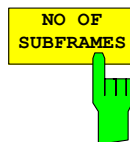

The *NO. OF SUBFRAMES* softkey opens an entry box for the number of subframes to be recorded for the averaging functions.

IEC/IEEE bus command: `:CONF:CDP:PVT:SFR <num_value>`

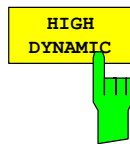

THE *HIGH DYNAMIC* softkey selects the high dynamic mode. The sweep mode is automatically set to single sweep

IEC/IEEE bus command: `:CONF:CDP:BTS:PVT:HDYN ON|OFF`

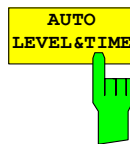

The *AUTO LEVEL & TIME* softkey starts the autorange routine for the reference level. This also creates the relationship between trigger and subframe start.

IEC/IEEE bus command: `:SENS:POW:ACH:AUTO:LTIM`

Signal statistic

MEAS key or MEAS hot key

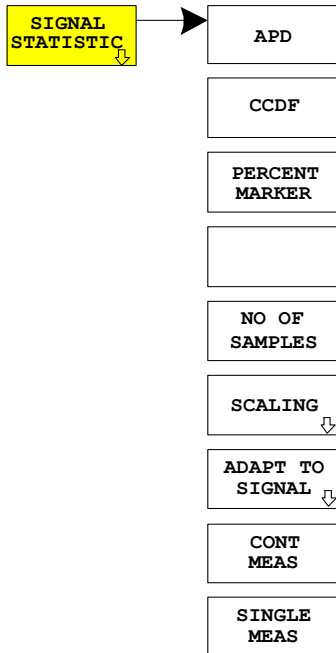

The *SIGNAL STATISTIC* softkey launches measurement of the distribution function of signal amplitudes (complementary cumulative distribution function). The measurement can be switched, using the menu softkey, to amplitude power distribution (APD).

For this measurement, a signal section of settable length is recorded continuously in a zero span, and the distribution of the signal amplitudes is evaluated. The recorded length and the display range of the CCDF can be set using the softkeys of the menu. The amplitude distribution is plotted logarithmically as a percentage of the amount by which a certain level is exceeded, starting with the average value of the signal amplitudes.

In addition, the crest factor, i.e. the difference between the maximum value and the mean power, is displayed in dB.

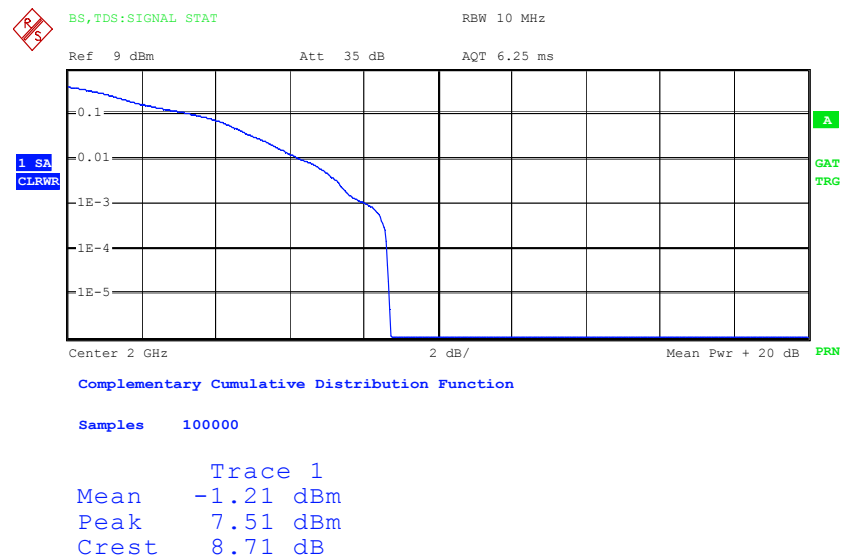

Fig. 5-6 CCDF of TD-SCDMA signal.

The softkey enables SPECTRUM mode with predefined settings:

The following user-specific settings are not modified so that the adaptation to the device under test is preserved:	
Reference Level + Rev Level Offset	
Center Frequency + Frequency Offset	
Input Attenuation + Mixer Level	
CCDF	ON
RBW	10 MHz
DETECTOR	SAMPLE
TRIGGER	EXTERN

Departing from this setting, the analyzer can be operated in all the functions it features in SPECTRUM mode, i.e. all measurement parameters can be adapted to a specific measurement.

To restore adapted measurement parameters, the following parameters are saved on exiting and are set again on re-entering this measurement:
 Level parameters
 Sweep time

Departing from this setting, the analyzer can be operated in all the functions it features in SPECTRUM mode, i.e. all measurement parameters can be adapted to a specific measurement.

IEC/IEEE bus command: :CONF:CDP:MEAS CCDF
 or
 :CALC:STAT:CCDF ON

Query of results:

```
:CALCulate:MARKer:X?
:CALCulate:STATistics:RESults? MEAN |
                                PEAK |CFACtor | ALL
MEAN  mean (r.m.s) measured power in dBm
      in the period of observation
PEAK  measured peak power in dBm
      in the period of observation
CFACtor determined CREST factor (i.e. ratio of
      peak power to mean power) in dB
ALL   results of all three named measure-
      ments, separated by a comma:
      <mean pow>, <peak pow>,
      <crest factor>
```

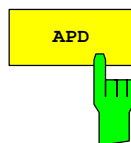

The *APD ON/OFF* softkey enables the amplitude probability distribution function .

IEC/IEEE bus command: :CALC:STAT:APD ON

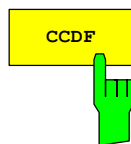

The *CCDF ON/OFF* softkey enables the complementary distribution function (complementary cumulative distribution function).

IEC/IEEE bus command: :CALC:STAT:CCDF ON

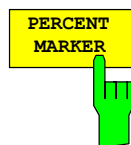

When the CCDF function is enabled, the *PERCENT MARKER* softkey supports positioning of marker 1 by entering a sought probability. In this way the power which exceeds a specified probability can be determined in a simple manner.

If marker 1 is disabled, it is enabled automatically.

IEC/IEEE bus command: :CALC:MARK:Y:PERC 0...100%

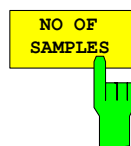

The *NO OF SAMPLES* softkey sets the number of power measured values to be taken into account for the calculation of the distribution function.

Note: *The overall measurement time is influenced by the selected number of samples as well as by the resolution bandwidth selected for the measurement, since the resolution bandwidth directly affects the sampling rate.*

IEC/IEEE bus command: :CALC:STAT:NSAM <value>

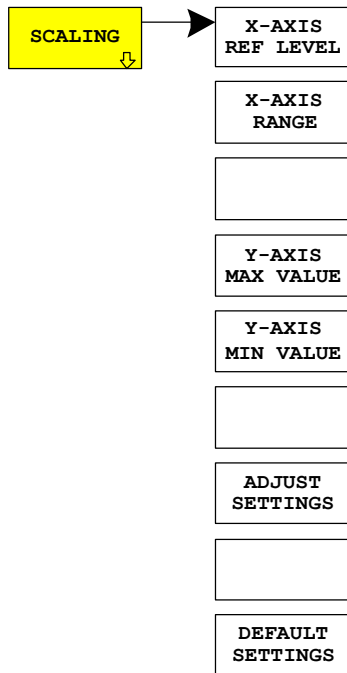

The *SCALING* softkey opens a menu on which the scaling parameters for the X-axis and the Y-axis can be modified.

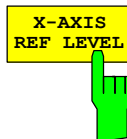

The *X-AXIS REF LEVEL* softkey changes the level settings of the unit and sets the maximum measurable power.

The function is identical to that of the *REF LEVEL* softkey on the *AMPT* menu.

This value is mapped to the right diagram border for the *APD* function. For the *CCDF* function, this value is not directly represented in the diagram because the X-axis is scaled relative to the measured *MEAN POWER*.

IEC/IEEE bus command: `:CALC:STAT:SCAL:X:RLEV <value>`

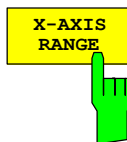

The *X-AXIS RANGE* softkey changes the level range that is to be covered by the distribution sampling function.

The function is identical to that of the *RANGE LOG MANUAL* softkey on the *AMPT* menu.

IEC/IEEE bus command: `CALC:STAT:SCAL:X:RANG <value>`

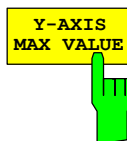

The *Y-AXIS MAX VALUE* softkey sets the upper limit of the displayed probability range.

The values on the Y-axis are normalized, i.e. the maximum value is 1.0. Since the Y-axis scaling is logarithmic, the spacing between the maximum and minimum values must be at least one decade.

IEC/IEEE bus command: `CALC:STAT:SCAL:Y:UPP <value>`

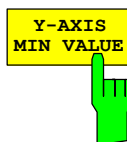

The *Y-AXIS MIN VALUE* softkey sets the lower limit of the displayed probability range.

Since the Y-axis scaling is logarithmic, the spacing between the maximum and minimum values must be at least one decade. Permissible range $0 < \text{value} < 1$.

IEC/IEEE bus command: `:CALC:STAT:SCAL:Y:LOW <value>`

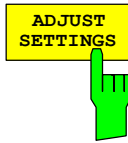

The *ADJUST SETTINGS* softkey optimizes the analyzer level settings according to the measured peak power in order to gain maximum sensitivity of the unit. The level range is set for the APD measurement according to the measured distance between the power peak value and the minimum value and for the CCDF measurement between the power peak value and the mean value in order to achieve maximum power resolution. In addition, the probability scale is adapted to the selected number of samples.

IEC/IEEE bus command: `CALC:STAT:SCAL:AUTO ONCE`

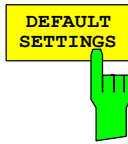

The *DEFAULT SETTINGS* softkey resets the scaling on the X-axis and the Y-axis to the default (PRESET) settings.

X-axis reference level: `-20 dBm`
 X-axis range for APD: `100 dB`
 X-axis range for CCDF: `20 dB`
 Y-axis for upper limit: `1.0`
 Y-axis for lower limit: `1E-6`

IEC/IEEE bus command: `:CALC:STAT:PRES`

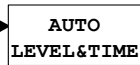

The *ADAPT TO SIGNAL* softkey opens a submenu for matching the reference level of the analyzer and configuration of gated sweep mode.

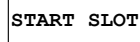

The *AUTO LEVEL & TIME* softkey starts the autorange routine for the reference level. This also creates the relationship between trigger and subframe start.



The *START SLOT* softkey allows entry of the start slot for gated sweep mode. The gated mode is on between START SLOT and STOP SLOT. For the remaining slots of a subframe the gated mode is off.



The *STOP SLOT* softkey allows entry of the stop slot for gated sweep mode. The gated mode is on between START SLOT and STOP SLOT. For the remaining slots of a subframe the gated mode is off.



IEC/IEEE bus commands:



`: [SENSe:] POWer:ACHannel:AUTO:LTIME`
`: [SENSe:] POWer:ACHannel:SLOT:START 1...7`
`: [SENSe:] POWer:ACHannel:SLOT:STOP 1...7`

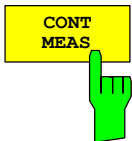
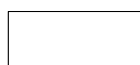

The *CONT MEAS* softkey starts the collection of new sequences of sample data and the calculation of the APD or CCDF trace, depending on the selected measurement. The next measurement is started automatically as soon as the indicated number of samples has been reached ("CONTInuous MEASUrement").

IEC/IEEE bus command: `:INIT:CONT ON;`
`:INIT:IMM`

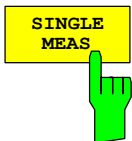

The *SINGLE MEAS* softkey starts the collection of one new sequence of sample data and the calculation of the APD or CCDF trace, depending on the selected measurement. The measurement terminates when the indicated number of samples is reached.

IEC/IEEE bus command: `:INIT:CONT OFF;`
`:INIT:IMM`

Code domain measurements on TD-SCDMA signals

The Application Firmware R&S FS-K76 features a code domain analyzer. This can be used for the measurements required by TD-SCDMA specifications for the power of the various codes and code channels (concentrated codes). In addition, the modulation quality (EVM and RHO factor), frequency errors, chip timing errors and peak code domain errors are determined. Constellation and bit stream evaluations are also available.

Use of an external trigger signal enables determination of the trigger-to-subframe time. The number of observed slots can be set with the *CAPTURE LENGTH* softkey.

Basically, the firmware differentiates between the following result classes for the evaluations:

- Results that consider the total signal over the whole observation period (all slots).
- Results that consider the total signal over one slot.
- Results that consider one channel over the whole observation period (all slots).
- Results that consider one channel over one slot.

The evaluations of the code domain analyzer are performed on a split screen. The screen is divided into two halves for this purpose.

The upper half of the screen (screen A) displays evaluations that vary by code. The lower half of the screen (screen B) displays all other evaluations.

Table 5-9 Evaluation on screen A

Evaluation on screen A	All channels	One channel	All slots	One slot
Code domain power	✓			✓
Code domain error power	✓			✓
Channel table	✓			✓

Table 5-10 Evaluation on screen B

Evaluation on screen B	All channels	One channel	All slots	One slot
Result summary	✓	✓	✓	✓
Power versus slot		✓	✓	
Power versus symbol		✓		✓
Composite EVM (modulation accuracy)	✓		✓	
Composite Constellation	✓			✓
Peak code domain error	✓		✓	
Symbol constellation		✓		✓
Symbol EVM		✓		✓
Bit stream		✓		✓

Depending on the symbol rate of a code channel, it has a different spreading factor and a different number of symbols per slot. The relationship can be seen in the table below.

Table 5–11 Relationship between spreading factor and symbol count plus data rate

Spreading factor	Symbols per slot	Data rate [kbps] QPSK	Data rate [kbps] 8PSK
16	44	17.6	26.4
8	88	35.2	52.8
4	176	70.4	105.6
2	352	140.8	211.2
1	704	281.6	422.4

The data rates in the table result from the bits per slot referred to a subframe length of 5 ms. In evaluation on the bottom screen, which uses symbols on the X axis, the maximum number of symbols varies with the symbol rate of the selected code channel.

Using the *SELECT CHANNEL* and *SELECT SLOT* softkeys, you can select the code channel and slot for which you want to display a result. In an example, code channel 1.16 is selected (code number 1 for spreading factor 16) and slot 2. Evaluation of code domain power is active on screen A and symbol EVM evaluation on screen B. So screen A shows the code domain power evaluation of slot 2. Code channel 1.16 is selected and shown in red. On the lower half of the screen you can see the symbol EVM evaluation of code channel 1.16 in slot 2 with 44 corresponding values.

The code domain analyzer can work in two modes. In *CODE CHAN AUTOSEARCH* mode it automatically searches for active channels in the whole code domain.

In the other mode, *CODE CHAN PREDEFINED*, you can determine the active code channels of a random slot by selectable and editable tables. The automatic channel search is then replaced by this user entry in the selected slot.

The code domain analyzer requires an active channel 1.16 (e.g. P–CCPCH1) and a valid midamble in slot 0 for synchronization. The parameters *SCRAMBLING CODE* and *MA SHIFTS CELL* must comply with the base station.

Presentation of evaluations – RESULTS

The *RESULTS* hotkey or the *MEAS* hotkey and then the *CODE DOM ANALYZER* softkey.

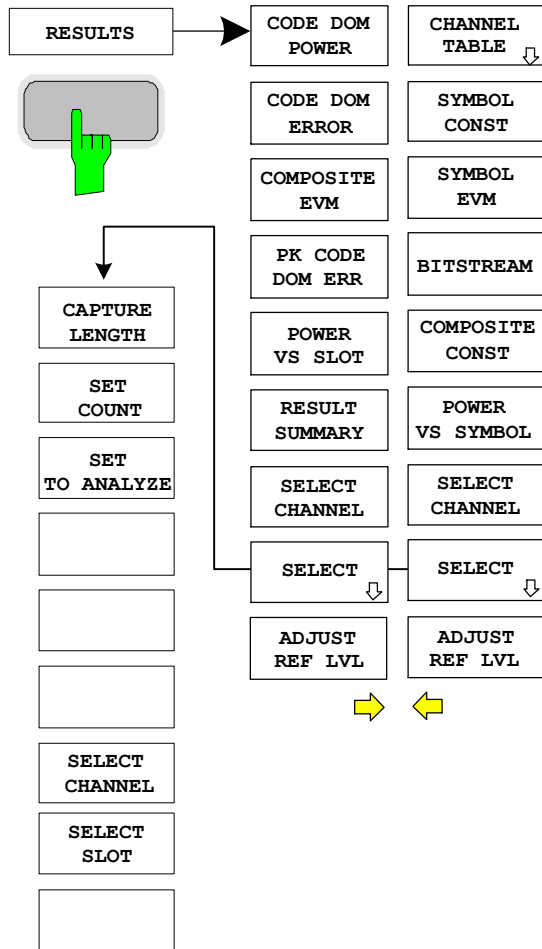

The *RESULTS* hotkey opens the submenu for choosing evaluation. The main menu shows the major evaluations for fast access; more detailed evaluations are available in the page menu.

You can choose from the following evaluations:

- CODE DOM POWER** Code domain power evaluation, depending on the *CODE PWR ABS / REL* softkey in relative or absolute scaling
- CODE DOM ERROR** Code domain error power evaluation
- COMPOSITE EVM** Error vector magnitude evaluation for each slot
- PK CODE DOM ERR** Peak of code domain error power evaluation for each slot
- POWER VS SLOT** Power of selected channel over all slots, depending on the *CODE PWR ABS / REL* softkey in relative or absolute scaling
- RESULT SUMMARY** Results in tabular form
- CHANNEL TABLE** Channel occupancy table in code order or midamble order
- SYMBOL CONST** Symbol constellation evaluation
- SYMBOL EVM** Error vector magnitude evaluation for each symbol of a slot
- BIT STREAM** Display of decided bits
- COMPOSITE CONST** Composite constellation evaluation
- POWER VS SYMBOL** Power of selected channel and selected slot over all symbols

By entering a channel number (*SELECT CHANNEL* softkey) you can select a channel for the evaluations *POWER VS SLOT*, *SYMBOL CONST*, *SYMBOL EVM*, *BIT STREAM* and *POWER VS SYMBOL*.

With the *SELECT SLOT* softkey you can select a slot for the evaluations *CODE DOM POWER*, *CODE DOM ERROR*, *CHANNEL TABLE*, *SYMBOL CONST*, *SYMBOL EVM*, *BIT STREAM* and *POWER VS SYMBOL*.

With *ADJUST REF LVL* you can optimally match the reference level of the unit to the signal level.

The following user-specific settings are not modified, so the matching to the device under test is preserved:
 Reference Level + Ref Level Offset
 Center Frequency + Frequency Offset
 Input Attenuation + Mixer Level

The following user-specific settings are adopted as follows:
 External trigger source is kept, all other trigger sources result in free run mode.
 Additional trigger settings are preserved.

To restore adjusted level parameters, they are saved on exiting the code domain analyzer and reset on re-entering the code domain analyzer.

The major measurement settings on which displays are based are summarized at the top of the diagram:

BS, TDS	:CODE POWER	DR	17.6 kbps
		Chan	1.16
dB TOT	CF 2.01000 GHz	Slot	0

Fig. 5-7 Function fields of diagrams

The meanings are as follows:

1. Column: Mobile radio system (base station TD-SCDMA)
 - Name of selected evaluation: e.g. BS, TDS
CODE POWER
 - (blank line)
 - Unit of Y axis: e.g. dB TOT for relative power to total power

2. Column: (blank line)
 - (blank line)
 - Center frequency of signal: e.g. CF 2.01000 GHz

3. Column: Data rate of selected channel: e.g. DR 17.6 kbps
 - Code number and spreading factor of selected channel: e.g. Chan 1.16
 - Number of selected slot: Slot 0

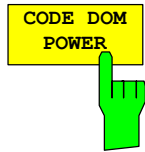

The *CODE DOM POWER* softkey selects evaluation of the code domain power (CDP).

In code domain power evaluation, the total signal is considered over precisely one slot. The power values of the different codes are determined and plotted in a diagram. In this diagram, the X axis is the code number and the Y axis a logarithmic level axis. The number of codes corresponds to the maximum spreading factor 16. You can set the slot to be evaluated with the *SELECT SLOT* softkey.

With the *CODE PWR ABS / REL* softkey you can switch between absolute and relative power readout. In relative power readout, the code power is referred to the mean total power of the data fields of the selected slot. The units of the Y axis are consequently dBm for absolute and dB TOT for relative evaluation.

The power values of the active and the unoccupied channels are shown in different colours. The following colours are defined:

- Yellow active channel
- Cyan unoccupied
- Red selected channel

A channel in *CODE CHAN AUTOSEARCH* mode (automatic channel search mode) is referred to as active if the minimum relative power you enter (see *INACT CHAN THRESHOLD* softkey) is exceeded and there is adequate signal/noise ratio. In *CODE CHAN PREDEFINED* mode, each code channel in the user-defined channel table is identified as active.

The results of code domain power evaluation are sorted and shown in ascending order of code numbers. All codes are projected to the spreading factor 16 for sorting. So channel 2.8 is between channels 3.16 and 6.16 for example.

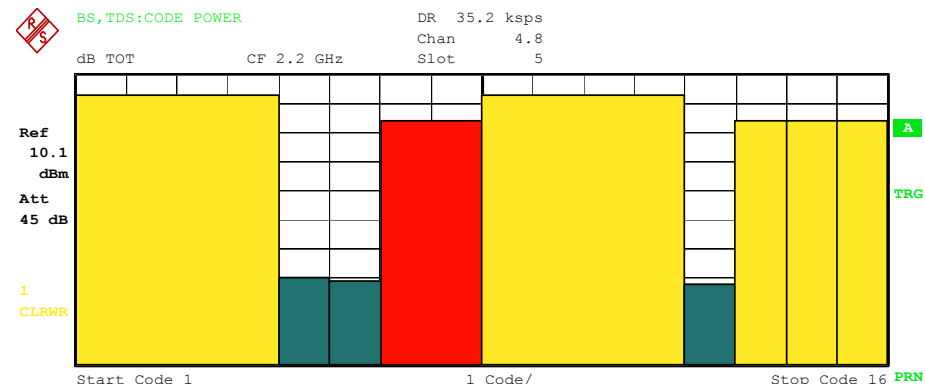

Fig. 5–8 CDP diagram

By entering a channel number (see *SELECT CHANNEL* softkey), you can select a channel for more detailed display. The codes of this channel are shown in red.

Selection of more detailed evaluations (e.g. *SYMBOL CONST*) for unoccupied codes is possible but not meaningful since the results are not valid.

IEC/IEEE bus command:

```
:CALC1:FEED "XPOW:CDP:RAT" (relative)
:CALC1:FEED "XPOW:CDP" (absolute)
```

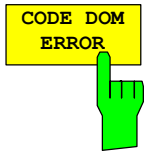

The *CODE DOM ERROR* softkey selects evaluation of code domain error power (CDEP).

The code domain error power measurement reads out the difference in power between a measured and an ideally generated reference signal for each code in dB. This is an error power, so active and inactive channels can be judged jointly at a glance in this evaluation. Analysis is solely in spreading factor 16.

In code domain error power evaluation, the total signal is considered over precisely one slot, the error power of the different codes is determined and plotted in a diagram. In this diagram, the X axis is the code number and the Y axis a logarithmic level axis with units of dB. The number of codes on the X axis corresponds to the maximum spreading factor 16. You can set the slot to be evaluated with the *SELECT SLOT* softkey.

The power values of the active and the unoccupied channels are shown in different colours. The following colours are defined:

- Yellow active channel
- Cyan unoccupied
- Red selected channel

A channel in *CODE CHAN AUTOSEARCH* mode (automatic channel search mode) is referred to as active if the minimum relative power you enter (see *INACT CHAN THRESHOLD* softkey) is exceeded and there is adequate signal/noise ratio. In *CODE CHAN PREDEFINED* mode, each code channel in the user-defined channel table is identified as active.

The results of code domain error power evaluation are sorted and shown in ascending order of code numbers in spreading factor 16.

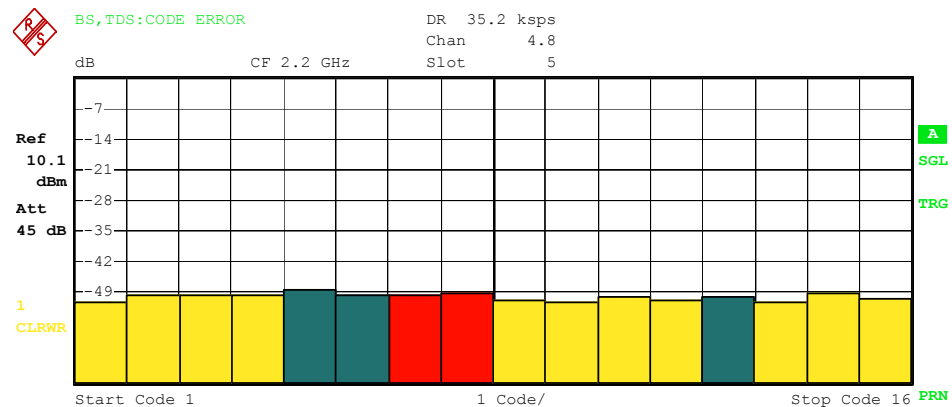
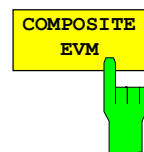

Fig. 5-9 CDEP diagram

By entering a channel number (see *SELECT CHANNEL* softkey), you can select a channel for more detailed display. The codes of this channel are shown in red.

IEC/IEEE bus command: :CALC1:FEED "XPOW:CDEP"



The *COMPOSITE EVM* softkey selects evaluation of error vector magnitude (EVM) over the total signal (modulation accuracy).

In composite EVM measurement, the square root is calculated from the squared error between the real and imaginary parts of the test signal and an ideally generated reference signal and normalized to the square root of the mean power of the reference signal.

The measured result consists of one composite EVM value per slot. You can set the number of slots by the *CAPTURE LENGTH* softkey. Subsequently, composite EVM evaluation considers the total signal over the entire period of

observation. No EVM value is output for inactive slots because there is no reference power present.

Only the channels detected as active are used to generate the ideal reference signal. In the case of a channel that is not detected as active because of low power for instance, the difference between the test signal and the reference signal and the composite EVM is therefore very large (see figure).

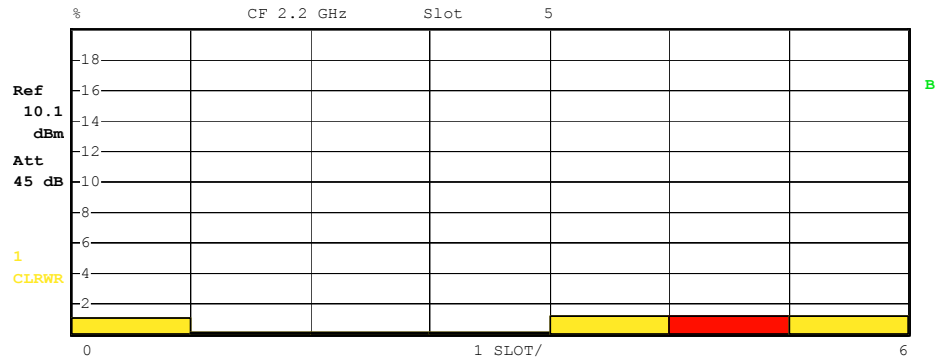

Fig. 5-10 Composite EVM diagram

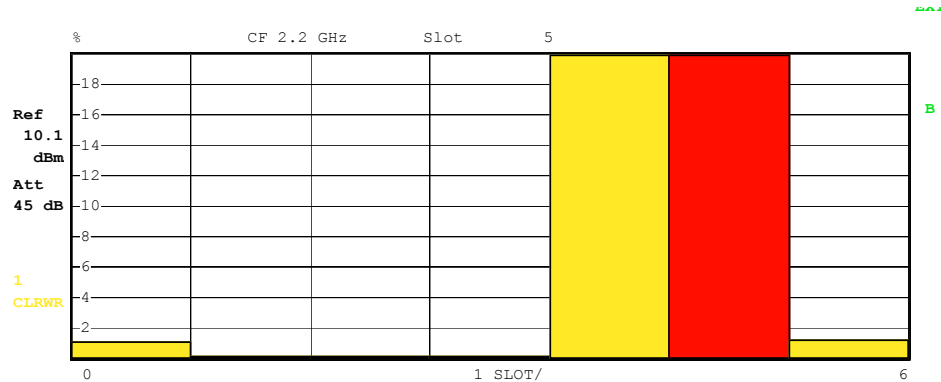
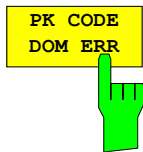

Fig. 5-11 Composite EVM diagram with unrecognized channels

Similar to selecting a code channel in the CDP or CDEP diagram, there is the option in the composite EVM diagram of selecting a slot. You select by entering the slot number (see *SELECT SLOT* softkey). The selected slot appears as a red bar.

IEC/IEEE bus command:

```
:CALC2:FEED "XTIM:CDP:MACC"
```



The *PK CODE DOM ERR* softkey selects peak code domain error evaluation.

The peak code domain error measurement reads out the maximum of the code domain error power measurement for each slot. This determines the difference in power between a measured and an ideally generated reference signal for each code in dB. Analysis is solely in spreading factor 16.

The measured result consists of a numeric value per slot for the peak code domain error. You can set the number of slots by the *CAPTURE LENGTH* softkey. Subsequently, peak code domain error evaluation considers the total signal over the entire period of observation. No peak code domain error value is output for inactive slots because there is no reference power present.

Only the channels detected as active are used to generate the ideal reference signal for peak code domain error. If an occupied code is not detected as active because of low power, the difference between the test signal and the reference

signal is very large. The R&S FS-K76 therefore shows a peak code domain error that is too high (see figure).

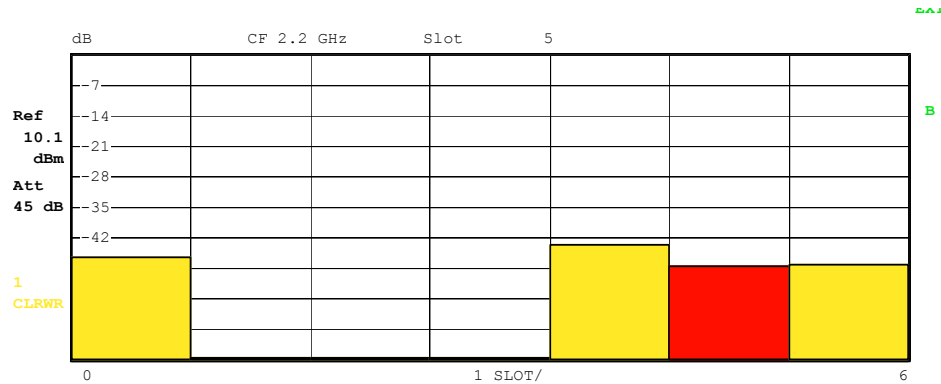

Fig. 5-12 Peak code domain error diagram

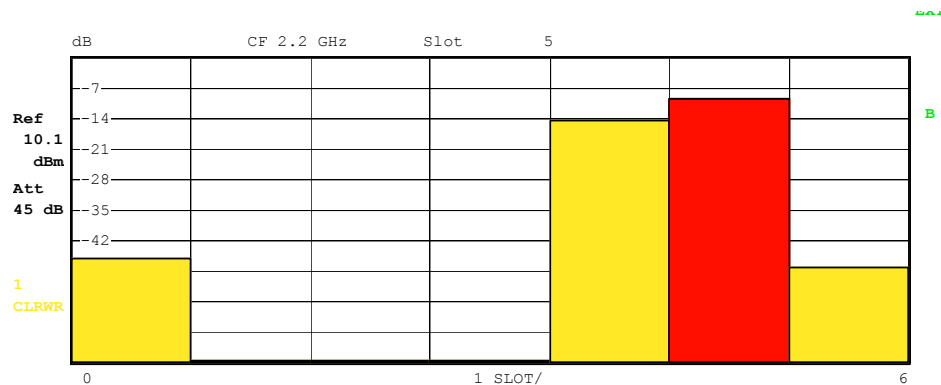
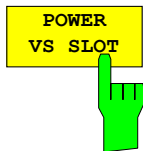

Fig. 5-13 Peak code domain error diagram with unrecognized channels

Similar to selecting a code channel in the CDP or CDEP diagram, there is the option in the peak code domain error diagram of selecting a slot. You select by entering the slot number (see *SELECT SLOT* softkey). The selected slot appears as a red bar.

IEC/IEEE bus command:

```
:CALC2:FEED "XTIM:CDP:ERR:PCD"
```



The *POWER VS SLOT* softkey activates power versus slot evaluation.

The power of the selected channel for each slot is averaged. With the *CODE PWR ABS / REL* softkey you can switch between absolute and relative power readout. In relative power readout, the code power in each slot is referred to the mean total power of the data fields of the slot. The units of the Y axis are consequently dBm for absolute and dB TOT for relative evaluation.

Note: *In relative power readout, the noise power in inactive slots of the selected channel is normalized to the total noise power. This produces relative power of typically -12 dB in inactive slots.*

Colours indicate whether the selected channel in the particular slot is active, inactive or alias power of another channel. Alias power is indicated if there is a channel with a different spreading factor in the place of the selected channel. The following colours are defined:

- Yellow active channel
- Cyan unoccupied

- Green alias power
- Red selected channel

The measured result consists of a numeric value per slot for the power value. You can set the number of slots by the *CAPTURE LENGTH* softkey. Subsequently, power versus slot evaluation considers one code channel over the entire period of observation.

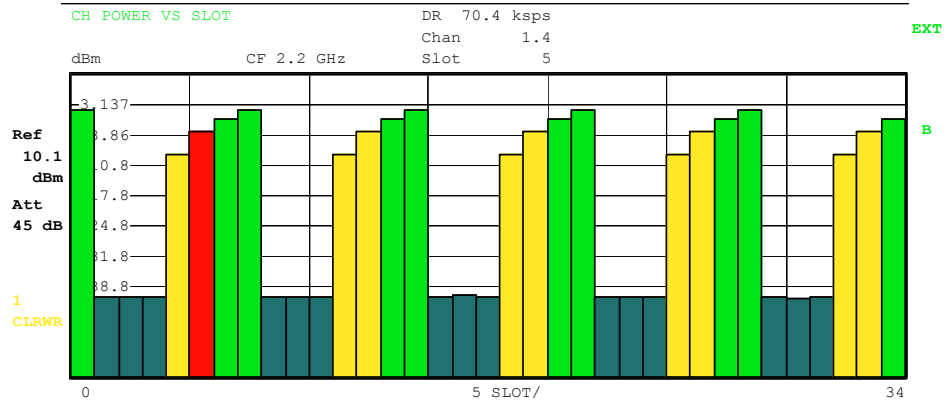

Fig. 5–14 Peak versus slot diagram with absolute power readout

Similar to selecting a code channel in the CDP or CDEP diagram, there is the option in the power versus slot diagram of selecting a slot. You select by entering the slot number (see *SELECT SLOT* softkey). The selected slot appears as a red bar.

```
IEC/IEEE bus command ::CALC2:FEED "XTIM:CDP:PVSlot:RAT"
                        (relative)
                        :CALC2:FEED "XTIM:CDP:PVSlot:ABS"
                        (absolute)
```

For compatibility reason with other 3G applications the default node
 CALC2:FEED 'XTIM:CDP:PVSL[:ABS]' is changed to
 CALC2:FEED 'XTIM:CDP:PVSL[:RAT]' since version 2.60/3.50.



The *RESULT SUMMARY* softkey selects numeric evaluation of all measured results. Evaluation is subdivided as follows:

RESULT SUMMARY TABLE		DR	17.6 kbps
		Chan	1.16
		Slot	4
		CF	2 GHz
GLOBAL RESULTS			
	Chip Rate Error	1.54 ppm	Trg to Frame 82 ns
Ref	SLOT RESULTS		
9.00 dBm	P Data	-1.17 dBm	Carr Freq Err -2.72 kHz
	P D1	-1.17 dBm	IQ Imbal/Offs 0.03/0.22 %
Att	P D2	-1.17 dBm	RHO 0.9999
35 dB	P Midamble	-1.17 dBm	Composite EVM 1.21 %
	Active Channels	8	Pk CDE(SF 16) -49.30 dB
1	CHANNEL RESULTS		
CLRWR	Channel.SF	1.16	Data Rate 17.6 kbps
	ChannelPwr Rel	-9.04 dB	ChannelPwr Abs -10.21 dBm
	Symbol EVM	0.72 %rms	Symbol EVM 1.27 %Pk

Fig. 5–15 Result summary

The first part shows measured results relating to the total signal:

Chip Rate Error: Chip rate error (1.28 Mcps) in ppm. A high chip rate error results in symbol errors and possibly in the CDP measurement not being able to synchronize.

Trg to Frame: Time offset from start of recorded signal segment to start of first slot. In the case of triggered data recording, this corresponds to the time offset from trigger to subframe start (+ trigger offset). If the analyzer was unable to synchronize to the TD-SCDMA signal, the value of Trg to Frame is meaningless. If the *FREE RUN* trigger is selected, dashes (—) are shown.

The second part shows measured results relating to all channels for the slot selected with the *SELECT SLOT* softkey:

P Data: Total power of data fields for selected slot

PD1/PD2: Power of data fields 1 and 2 for selected slot

P Midamble: Power of midamble field for selected slot

Active Channels: Number of active channels for selected slot

Carr Freq Err: Frequency error for selected slot. This is the sum of the frequency error of the analyzer and that of the device under test.

IQ Imbal/Offs: IQ imbalance and IQ DC offset

RHO: Quality parameter RHO for selected slot

Composite EVM: Total signal error vector magnitude for selected slot.

Pk CDE (SF 16) : Peak code domain error in spreading factor 16 for selected slot

The third part of *RESULT SUMMARY* shows the results of measurements on the selected channel in the selected slot.

Data Rate: Data rate as a function of spreading factor and modulation class of channel

Channel SF: Number of channel and its spreading factor

Channel Power Rel: Relative channel power referred to mean power of data fields

of selected slot

Channel Power Abs: Absolute channel power

Symbol EVM: Peak and mean EVM for selected channel in selected slot

```
IEC/IEEE bus command: :CALC2:FEED "XTIM:CDP:ERR:SUMM"  
                      :CALC2:MARK1:FUNC:CDP:BTS:RES?  
                      SLOT | PDAT | PD1 | PD2 | PMID |  
                      RHO | MACC | PCD | FERR | CERR | TFR  
|                       IQIMB | IQOF | ACT | SRAT | CHAN  
|                       | SFAC | CDPR | CDP | EVMR | EVMP
```

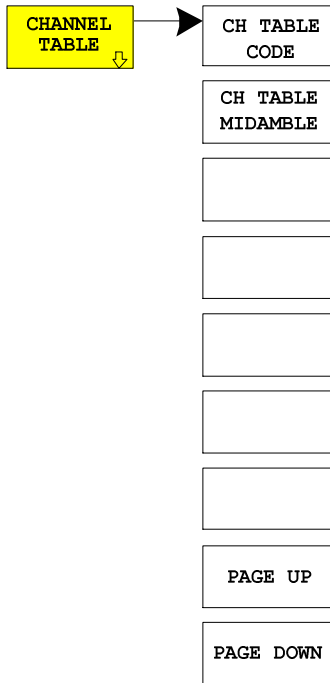

The *CHANNEL TABLE* softkey selects channel occupancy table evaluation.

The channel occupancy table can hold a maximum of 32 entries, corresponding to 16 midambles and 16 code channels. Channel occupancy table evaluation considers the total signal over precisely one slot. You set the slot to be evaluated by the *SELECT SLOT* softkey.

A data channel in *CODE CHAN AUTOSEARCH* mode is identified as active if it exhibits minimum power (see *INACT CHAN THRESHOLD* softkey) and adequate signal/noise ratio. In *CODE CHAN PREDEFINED* mode, all active code channels contained in the predefined channel table are identified as active in the selected slot.

You can select the sorting of the channel table with the *CH TABLE CODE* and *CH TABLE MIDAMBLE* softkeys.

The midambles are listed first in code order. The midambles are sorted in ascending order by their midamble shift. They are followed by the active channels. The active channels are projected to the spreading factor 16 and sorted in ascending order of code numbers.

The inactive channels come at the end.

BS, TDS: CHANNEL TAB

Chan 1.4
Slot 5

CF 15.36 MHz

	Type	Chan.SF	Data Rate kbps	Mod Type	Pwr.Abs dBm	Pwr.Rel dB	MA.shift	ΔMiD1 dB	ΔMiD2 dB	
Ref	Midamble	---	---	---	-9.51	-4.78	1	-0.03	-0.04	A
4.00	Midamble	---	---	---	-15.53	-10.80	7	0.05	0.02	
dBm	Midamble	---	---	---	-9.50	-4.77	9	0.04	0.05	
Att	Midamble	---	---	---	-15.52	-10.78	14	-0.02	-0.01	TRG
35 dB	Midamble	---	---	---	-15.54	-10.80	15	-0.01	-0.02	
	Midamble	---	---	---	-15.53	-10.79	16	-0.05	-0.04	
1	DPCH	1.4	70.40	QPSK	-9.47	-4.74	1	---	---	
CLRWR	DPCH	4.8	35.20	QPSK	-15.57	-10.84	7	---	---	
	DPCH	3.4	70.40	QPSK	-9.55	-4.82	9	---	---	
	DPCH	14.16	17.60	QPSK	-15.50	-10.76	14	---	---	PRN

Fig. 5-16 Channel table in code order

In midamble order the codes are listed after each midamble. Common and default midamble allocation is automatically distinguished. The allocation of codes to midambles for these two cases can be taken from TD-SCDMA specifications. If neither a common nor a default midamble allocation is found, sorting is in code order.

BS, TDS: CHANNEL TAB

CF 15.36 MHz Chan 1.4 Slot 5

	Type	Chan.SF	Data Rate kbps	Mod Type	Pwr.Abs dBm	Pwr.Rel dB	MA.shift	ΔMiD1 dB	ΔMiD2 dB	
Ref	Midamble	---	---	---	-9.51	-4.78	1	-0.04	-0.04	A
4.00 dBm	DPCH	1.4	70.40	QPSK	-9.47	-4.74	1	---	---	
Att	Midamble	---	---	---	-15.52	-10.80	7	0.05	0.03	TRG
35 dB	DPCH	4.8	35.20	QPSK	-15.56	-10.83	7	---	---	
	Midamble	---	---	---	-9.50	-4.77	9	0.04	0.05	
	DPCH	3.4	70.40	QPSK	-9.54	-4.81	9	---	---	
1	Midamble	---	---	---	-15.51	-10.78	14	-0.03	-0.01	
CLRWR	DPCH	14.16	17.60	QPSK	-15.49	-10.77	14	---	---	
	Midamble	---	---	---	-15.53	-10.80	15	-0.01	-0.02	
	DPCH	15.16	17.60	QPSK	-15.51	-10.79	15	---	---	PRN

Fig. 5-17 Channel table in midamble order

The following parameters are determined by CDP measurement for the channels:

Type: Type of channel (midamble, DPCH or special channel)

Chan SF: Channel number (1 to spreading factor) including spreading factor of channel in Notation Chan SF

Data Rate: Data rate at which channel is transmitted

Mod Type: Modulation method of channel (QPSK or 8PSK)

Pwr Abs/Pwr Rel: Absolute and relative power of channel (referred to total power of data fields)

Ma Shift: Midamble shift. For code channels, this is the shift of the associated midamble if a common or default midamble allocation is detected.

TD-SCDMA specifications state that a midamble and its code channels must exhibit the same power. The following two parameters are shown if a common or default midamble allocation is detected.

ΔMiD1: Power offset between midamble and sum power of its channels in data field 1

ΔMiD2: Power offset between midamble and sum power of its channels in data field 2

A data channel in *CODE CHAN AUTOSEARCH* mode is identified as active if it exhibits minimum power (see *INACT CHAN THRESHOLD* softkey) and adequate signal/noise ratio. In *CODE CHAN PREDEFINED* mode, all active code channels contained in the predefined channel table are identified as active.

IEC/IEEE bus commands:

```
:CALC1:FEED "XTIM:CDP:ERR:CTAB"  
:CONF:CDP:CTAB:ORD CODE  
:CONF:CDP:CTAB:ORD MID
```

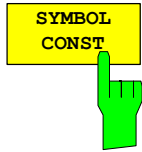

The *SYMBOL CONST* softkey selects evaluation of the constellation diagram at symbol level. The diagram is normalized by the square root of the mean symbol power.

Evaluation of the symbols is performed for the selected channel (*SELECT CHANNEL* softkey) and the selected slot (*SELECT SLOT* softkey). This evaluation consequently considers results of one channel for one slot. For orientation, the unit circle is added to the figure.

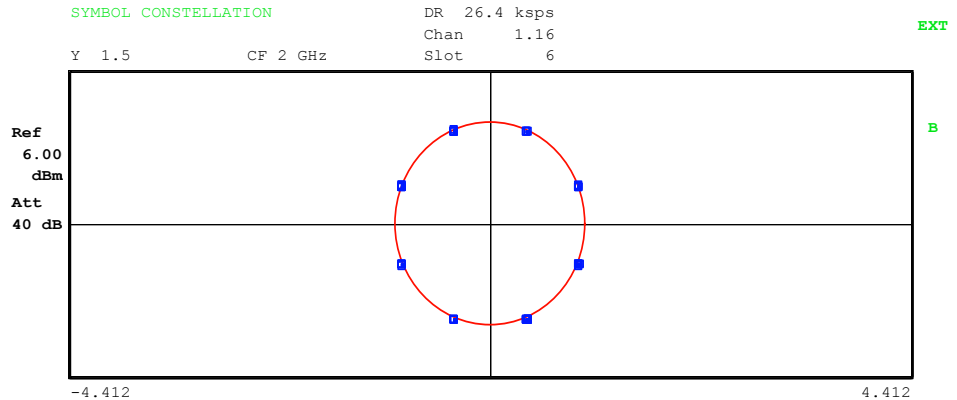
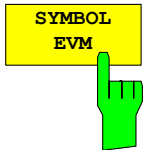

Fig. 5–18 Symbol constellation diagram for 8PSK modulation

IEC/IEEE bus command:

```
:CALC2:FEED "XTIM:CDP:SYMB:CONS"
```



The *SYMBOL EVM* softkey selects symbol error vector magnitude evaluation. Evaluation of the EVM is performed for the selected channel (*SELECT CHANNEL* softkey) and the selected slot (*SELECT SLOT* softkey). This evaluation consequently considers results of one channel for one slot.

Evaluation of symbol error vector magnitude for unoccupied codes is not meaningful, since the results are not valid.

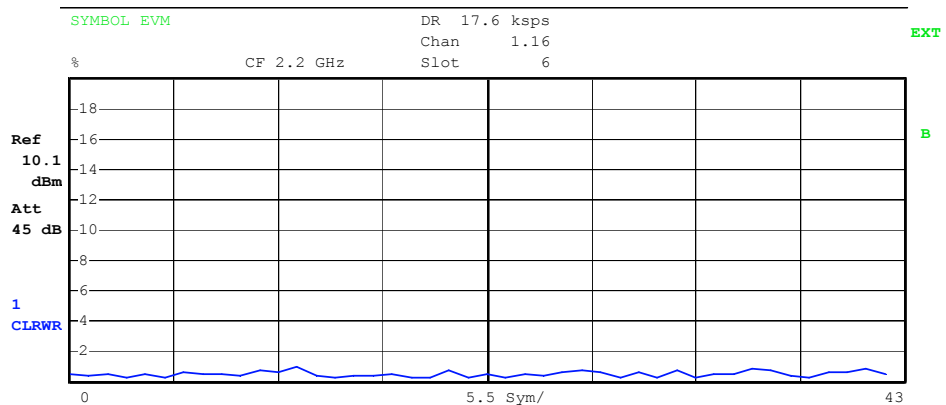

Fig. 5–19 Error vector magnitude for one channel of slot

IEC/IEEE bus command:

```
:CALC2:FEED "XTIM:CDP:SYMB:EVM"
```



The *BIT STREAM* softkey selects evaluation of the bit stream from the demodulated received signal.

Evaluation of the decided bits is performed for the selected channel (*SELECT CHANNEL* softkey) and the selected slot (*SELECT SLOT* softkey). This evaluation consequently considers results of one channel for one slot.

Depending on the spreading factor of the channel, a slot may contain between 44 and 704 symbols. In QPSK modulated channels, a symbol always consists of two bits. In 8PSK modulated channels, a symbol always consists of three bits. The allocation of symbols to bits is according to TD-SCDMA specifications.

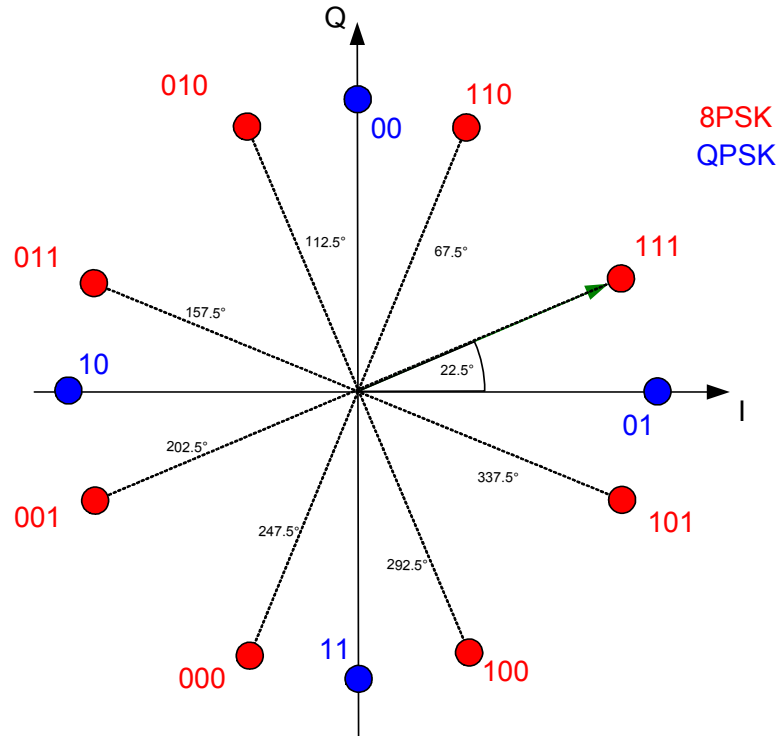

Fig. 5-20 Phasor diagram for QPSK and 8PSK including bit values

The marker can be used to scroll in the bit stream.

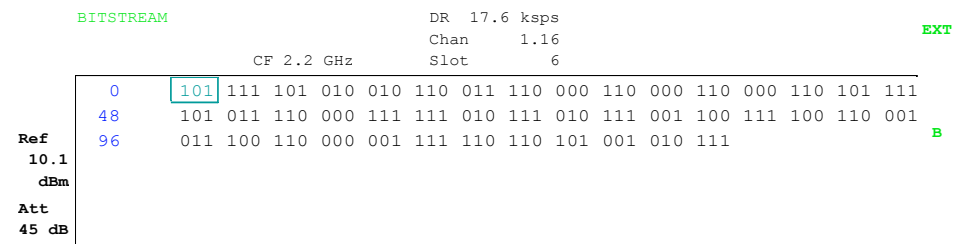
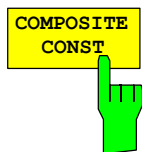

Fig. 5-21 Demodulated bits for channel with 8PSK modulation

IEC/IEEE bus command: :CALC2:FEED "XTIM:CDP:BSTR"



The *COMPOSITE CONST* softkey selects the evaluation of the constellation diagram at chip level.

With *COMPOSITE CONST*, the total signal is taken into account over the selected slot (*SELECT SLOT* softkey). A constellation point is entered in the diagram for each of the 704 data chips. The diagram is normalized by the square root of the mean chip power.

For orientation, the unit circle is added to the figure.



Bild 5–22 Composite Constellation Diagram

Note: *If only one channel is active in the selected slot, all constellation points are situated on the unit circle and occupy one display pixel, if noise is low. If so, it would be reasonable to switch to symbol constellation for a better view.*

IEC/IEEE bus command: :CALC2:FEED"XTIM:CDP:COMP:CONS"

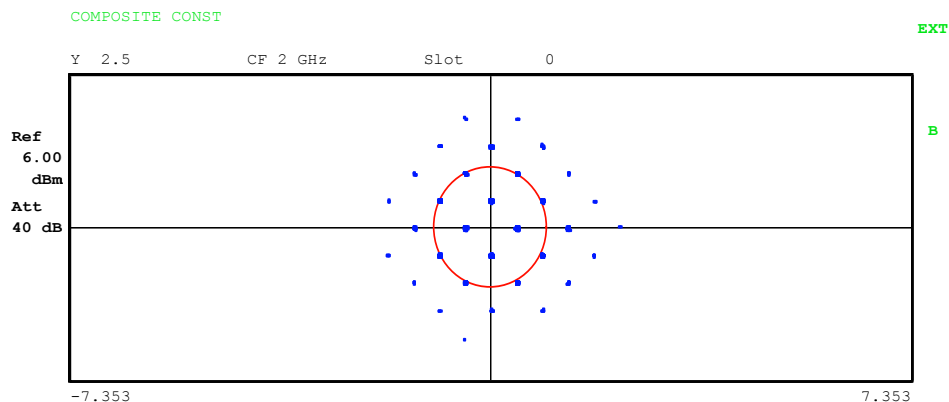
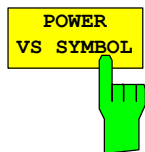

The *POWER VS SYMBOL* softkey selects power versus symbol evaluation. Evaluation outputs the absolute power in dBm at every symbol time for the selected channel (*SELECT CHANNEL* softkey) in the selected slot (*SELECT SLOT* softkey). This evaluation consequently considers results of one channel for one slot.

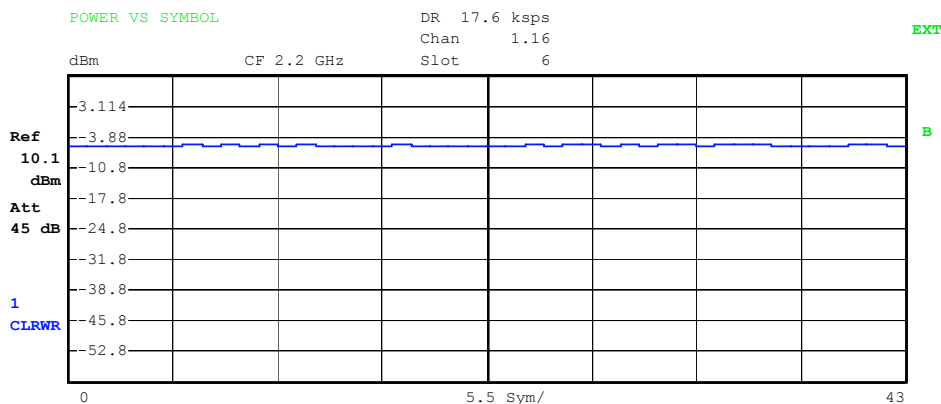
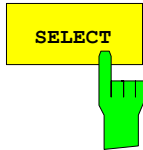
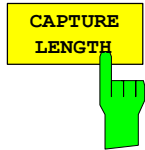

Fig. 5–23 Power versus symbol for one channel of one slot

IEC/IEEE bus command: :CALC2:FEED "XTIM:CDP:PVSY"



The *SELECT* softkey opens a submenu to define the capture configuration and the selection of slot and channel for the evaluation.



The *CAPTURE LENGTH* softkey allows entry of the number of slots to be captured. The range is from 2 to 63. For all evaluations with one value per slot on the X axis, the maximum value on the X axis is the set *CAPTURE LENGTH* -1.

IEC/IEEE bus command: `: [SENSe:]CDPower:IQLength 2...63`

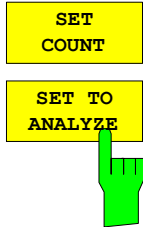

This function offers the possibility for the **R&S FSQ** to capture up to 11970 slots (correspond to 8 seconds) with a *SINGLE SWEEP* and then post process all the data with *SET TO ANALYZE*.

If the *SET COUNT* is set to 1 (default value), the device behaves as before and with the *CAPTURE LENGTH* the number of PCG can be set.

For R&S FSQ the *SET COUNT* can be adjusted in the range of 1...190. Is the *SET COUNT* greater than 1 the *CAPTURE LENGTH* will be implicitly set to 63 slots and become unavailable. The *SET COUNT* defines then how many *SETS* of 63 slots shall be captured consecutively into the IQ RAM of the R&S FSQ. With the *SET TO ANALYZE* softkey the set for which the results are calculated can be defined. The range is from 0... (*SET COUNT*-1).

IEC-Bus-command: `: [SENSe:]CDPower:SET:COUNT 1..190 (FSQ)`
`: [SENSe:]CDPower:SET:[VALue]`
`<numeric_value> (FSQ)`

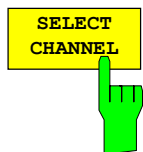

You can use the *SELECT CHANNEL* softkey to select a channel. All evaluations that consider results for a channel specify the results for the newly selected channel: *POWER VS SLOT*, *POWER VS SYMBOL*, *RESULT SUMMARY*, *BIT STREAM*, *SYMBOL CONST* and *SYMBOL EVM*.

In the evaluations *CODE DOM POWER*, *CODE DOM ERROR* and *CHANNEL TABLE* (all on screen A), the selected channel is marked red.

Entry of a channel is decimal in the form `<Channel number>.<Spreading factor>` with a decimal point as the demarcator. Instead of a channel number, you can enter a code number without any decimal point and spreading factor. This is referred to the spreading factor 16.

If the current channel table contains a concentrated channel to which the selected channel belongs, this concentrated channel is displayed with the associated channel number and spreading factor in the function field and marked red in the evaluations.

Example 1:

Entry of channel 5.8

Channel 3.4 is active in the channel table and also includes channels 5.8 and 6.8.

Channel 3.4 is shown in the entry box and marked red on screen A.

Example 2:

Entry of code number 9

Channel 3.4 is active in the channel table and includes code numbers 9, 10, 11 and 12.

Channel 3.4 is shown in the entry box and marked red on screen A.

The rotating wheel action depends on the evaluation on screen A and is geared

to the graphic display. The rotating wheel always selects the adjacent channel. In the channel table, the rotating wheel is used to scroll through the list.

IEC/IEEE bus command: `:SENS:CDP:CODE 1...16`

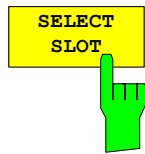

The *SELECT SLOT* softkey serves for selecting a slot. Entry of the slot is decimal. Here the range is from 0 to (IQ capture length – 1) (see *CAPTURE LENGTH* softkey). All evaluations that consider results for a slot specify the results for the newly selected slot: *CODE DOM POWER*, *CODE DOM ERROR*, *CHANNEL TABLE*, *POWER VS SYMBOL*, *RESULT SUMMARY*, *BIT STREAM*, *SYMBOL CONST* and *SYMBOL EVM*.

In the evaluations *POWER VS SLOT*, *COMPOSITE EVM* and *PK CODE DOM ERR* the selected slot is marked red.

IEC/IEEE bus command: `:SENS:CDP:SLOT 0 ... (IQ_CAPTURE_LENGTH-1)`

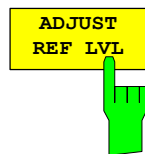

The *ADJUST REF LVL* softkey matches the reference level of the analyzer to the measured channel power. This ensures that the RF attenuation and reference level settings are optimally matched to the signal level without the analyzer being overloaded or the dynamic response limited by too low a signal/noise ratio.

IEC/IEEE bus command: `:SENS:POW:ACH:PRES:RLEV`

Configuration of measurements

CHAN CONF hotkey

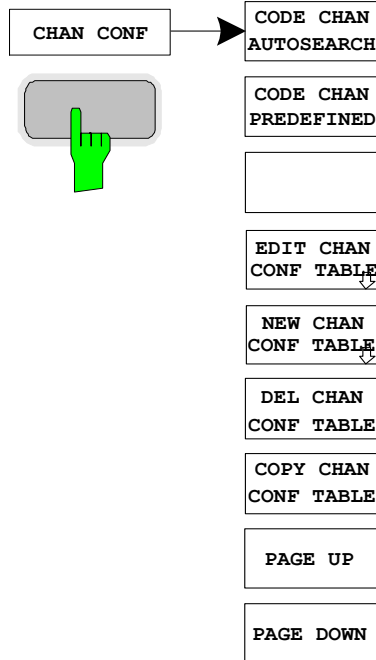

The *CHAN CONF* hotkey opens a submenu with configuration options for the channel search. In this submenu you can select predefined channel tables that are then taken as a basis for measurements by the code domain analyzer.

When you first press the hotkey, a table opens with the channel tables stored on the harddisk of the instrument. The table is merely an overview; to select one of the tables for a measurement, you must first press the *CODE CHAN PREDEFINED* softkey. The *RECENT* entry is the channel table of the last code domain power analysis that was performed.

IEC/IEEE bus command:

```
:CONF:CDP:BTS:CTAB:CAT?
```



The *CODE CHAN AUTOSEARCH* softkey supports measurements of the code domain power analyzer in automatic search mode. This mode searches the whole code domain (all permissible symbol rates and channel numbers) for active channels. A channel is active when the minimum power you enter, referred to the total power, is exceeded (see *INACT CHAN THRESHOLD* softkey) and there is adequate signal/noise ratio.

CODE CHAN AUTOSEARCH is the default search mode with which CDP analysis starts. It is used primarily to give you an overview of the channels contained in the signal. If the signal contains channels that are not detected as active in automatic search mode, CDP analysis can be performed with predefined channel configurations by changing to *CODE CHAN PREDEFINED* mode.

IEC/IEEE bus command:

```
:CONF:CDP:BTS:CTAB:STAT OFF
```

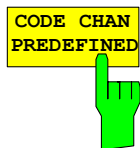

The *CODE CHAN PREDEFINED* softkey switches CDP analysis to the measuring mode with the help of predefined channel tables. In this mode there is no search for active channels in the code domain for the selected slot, instead the channels of a table defined prior to a measurement are assumed to be active.

When you press the softkey, a table opens with all channel tables stored on the instrument. CDP analysis is switched to predefined channel table mode. The last table of the automatic search mode is initially taken as a basis for the measurement. This table is available under *RECENT*.

You switch to one of the predefined channel tables by selecting the appropriate table entry and pressing one of the unit keys or Enter. From the next measurement onwards, the selected channel table is taken as a basis for evaluation for the selected slot. A tick marks the selected channel table.

IEC/IEEE bus command:

```
:CONF:CDP:BTS:CTAB1:STAT ON
```

```
:CONF:CDP:BTS:CTAB:SEL "MY_FIRST_CH_TAB"
```

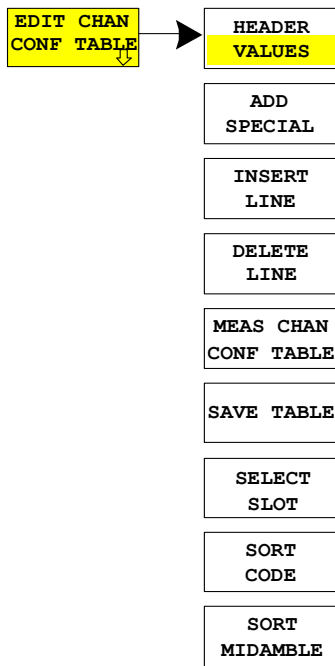

The *EDIT CHAN CONF TABLE* softkey opens the selected channel table, in which the channel configuration can be edited. In addition, a submenu opens with the softkeys required for editing the channel table.

EDIT CHANNEL TABLE					
NAME:	My_First_Channel_Table			MA SHIFTS CELL	16
COMMENT:	Base Station Test 1				
TYPE	CHAN.SF	Modulation Type	Data Rate [kbps]	Midamble Shift	STATUS
MIDAMBLE	--	--	--	1	ACTIVE
PCCPCH	1.16	QPSK	17.6	--	ACTIVE
DPCH	2.16	QPSK	17.6	--	ACTIVE

Fig. 5–24 Table for editing channel configuration

Basically any of the channel tables stored on the instrument can be edited as you wish. The edited table is not stored automatically on the harddisk of the instrument, first you must press the *SAVE TABLE* softkey. This avoids accidental overwriting of a table.

If a table is edited that is currently the basis for code domain power analysis, the edited table is used for the next measurement immediately after it is saved. So the effects of the changes in the table are immediately visible. Here again, the edited table is not saved on the harddisk of the instrument until you press the *SAVE TABLE* softkey.

If a table is edited that is stored on the harddisk of the instrument but not currently activated, the changes will not be visible until it has been saved (*SAVE TABLE* softkey) and then activated.

If you change the channel number or spreading factor, a check for code domain conflicts is made after you press the unit key. If a code domain conflict is detected, the channels causing the conflict are identified by an asterisk. This allows you to eliminate any code domain conflicts. If a table with code domain conflicts is used for CDP analysis, the results are invalid.

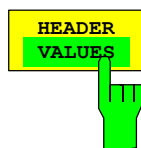

The *HEADER / VALUES* softkey sets the focus of the edit option either on the table entries or the table header.

Editing table header (*HEADER*):

This means editing values for the whole channel table. The following entries are available (confirm an entry with the help of the unit keys):

NAME: Name of the channel table. Overwriting of ready saved tables can be avoided by changing the name of a table. A table name must not consist of more than eight characters.

COMMENT: Comment on the channel table, e.g. description of slot allocation.

MA SHIFTS CELL: Maximum number of usable midambles of the base station. In mode *CODE CHAN PREDEFINED* this entry replaces the value in the *SETTINGS* menu. (see softkey *SETTINGS, MA SHIFTS CELL*).

IEC/IEEE bus command:

```
:CONF:CDP:BTS:CTAB:NAME "NEW_TAB"  
:CONF:CDP:BTS:CTAB:COMM "comment"  
:CONF:CDP:BTS:CTAB:MSH <numeric>
```

Editing table entries (*VALUES*):

This means editing the actual data of the channel table. The following entries are available for each of the channels in the table (confirm an entry with the help of the unit keys):

TYPE: Channel type. Midamble or code channel can be selected. Special channels are identified by their names (P-CCPCH, S-CCPCH, FPACH, PDSCH, PICH). All other channels are entered as DPCH (dedicated physical channel) for normal data channels.

CHAN SF: The channel number and the spreading factor are entered for the channel in this column. For an entry without a decimal point the spreading factor is 16. Invalid entries are rejected.

MODULATION TYPE: Modulation type of the channel. You can choose between QPSK, 8PSK and 16QAM.

DATA RATE: Data rate of the channel. This is a direct function of the spreading factor and modulation type of the channel, so it cannot be edited.

MIDAMBLE SHIFT: Here you can enter the midamble shift number for a midamble channel type. Possible entries are from 1 to the maximum number of midambles (see *SETTINGS*,

STATUS: The entry can be set active or inactive. Inactive entries are not used in measurements.

IEC/IEEE bus commands

```
:CONF:CDP:BTS:CTAB:DATA  
2,4,1,1,1,1,0,0,  
2,4,2,1,1,1,0,0
```

' Defines two data channels with QPSK modulation



The *ADD SPECIAL* softkey allows you to add special channels to the channel table.

ADD SPECIAL
P-CCPCH
S-CCPCH
FPACH
PDSCH
PICH
Midamble

Fig. 5-25 Table of special channels

All channels not listed are entered as DPCH by the *INSERT LINE* softkey. Stating special data channels only serves for the purpose of an overview in R&S FS-K76. Code domain measurements do not distinguish between special channels and data channels with the same parameters.

IEC/IEEE bus command: -- (integrated in command
:CONF:CDP:BTS:CTAB:DATA)

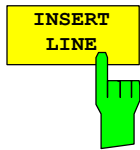

The *INSERT LINE* softkey adds a new entry to the table. Entries can be made in any order. A channel is only included in CDP analysis if all required entries are present in the list.

IEC/IEEE bus command: —

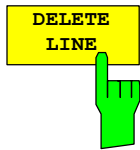

The *DELETE LINE* softkey deletes the selected line from the table.

IEC/IEEE bus command: --



The *MEAS CHAN CONF TABLE* softkey starts a measurement in *CODE CHAN AUTOSEARCH* mode. The measurement results are adopted in the opened channel table.

IEC/IEEE bus command: --

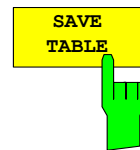

The *SAVE TABLE* softkey saves the table with its specified name. Caution: Editing channel models and saving them under the original name will result in the models being overwritten.

IEC/IEEE bus command: -- (automatic with remote control)

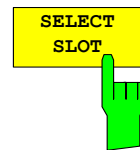

The *SELECT SLOT* softkey serves for selecting the slot on which the channel table is applied. At the same time this is the slot on which the slot-dependent evaluations are made.

IEC/IEEE bus command: --

Configuration of application firmware – SETTINGS

SETTINGS hotkey

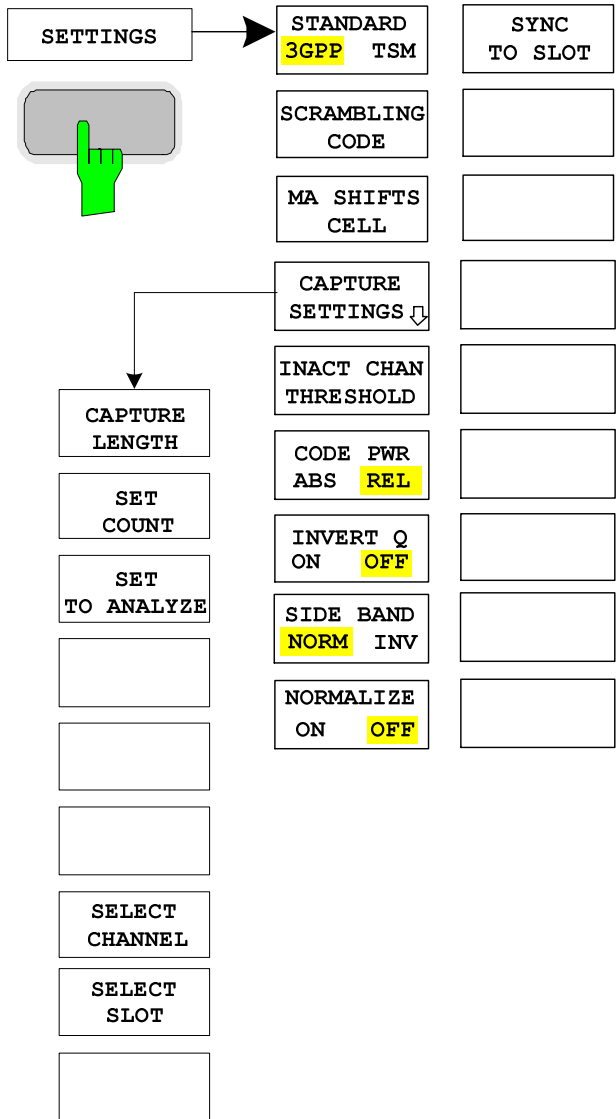

The *SETTINGS* hotkey opens a submenu for setting the measurement parameters of the application firmware.



The *STANDARD softkey* selects, whether the measurements are based on the 3GPP standard or the TSM standard. At the moment, this affects the spectrum emission mask measurement only.

IEC/IEEE bus command: :SENS:CDP:STAND GPP | TSM

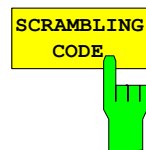

The *SCRAMBLING CODE softkey* allows entry of the scrambling code of the base station. Entry of the scrambling code is decimal.

IEC/IEEE bus command: :SENS:CDP:SCOD 0...127

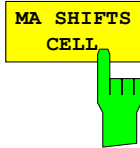

The *MA SHIFTS CELL* softkey allows entry of the maximum number of usable midamble shifts of the base station. In the mode *CODE CHAN PREDEFINED* this value will be replaced by the entry in the channel table.

IEC/IEEE bus command: :SENS:CDP:MSH 2...16

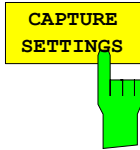

The *CAPTURE SETTINGS* softkey opens a submenu to define the capture configuration and the selection of slot and channel for the evaluation.

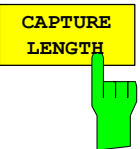

The *CAPTURE LENGTH* softkey allows entry of the number of slots to be captured. The range is from 2 to 63. For all evaluations with one value per slot on the X axis, the maximum value on the X axis is the set *CAPTURE LENGTH* - 1.

IEC/IEEE bus command: :SENS:CDP:IQL 2...63

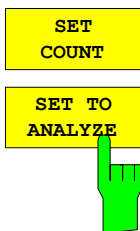

This function offers the possibility for the **R&S FSQ** to capture up to 11970 slots (correspond to 8 seconds) with a *SINGLE SWEEP* and then post process all the data with *SET TO ANALYZE*.

If the *SET COUNT* is set to 1 (default value), the device behaves as before and with the *CAPTURE LENGTH* the number of PCG can be set.

For R&S FSQ the *SET COUNT* can be adjusted in the range of 1...190. Is the *SET COUNT* greater than 1 the *CAPTURE LENGTH* will be implicitly set to 63 slots and become unavailable. The *SET COUNT* defines then how many SETS of 63 slots shall be captured consecutively into the IQ RAM of the R&S FSQ. With the *SET TO ANALYZE* softkey the set for which the results are calculated can be defined. The range is from 0... (*SET COUNT*-1).

IEC-Bus-command: :SENS:CDP:SET:COUN 1..190 (FSQ)
 :SENS:CDP:SET:VAL <numeric_value>

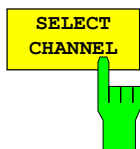

You can use the *SELECT CHANNEL* softkey to select a channel. All evaluations that consider results for a channel specify the results for the newly selected channel: *POWER VS SLOT*, *POWER VS SYMBOL*, *RESULT SUMMARY*, *BIT STREAM*, *SYMBOL CONST* and *SYMBOL EVM*.

In the evaluations *CODE DOM POWER*, *CODE DOM ERROR* and *CHANNEL TABLE* (all on screen A), the selected channel is marked red.

Entry of a channel is decimal in the form <Channel number>.<Spreading factor> with a decimal point as the demarcator. Instead of a channel number, you can enter a code number without any decimal point and spreading factor. This is referred to the spreading factor 16.

If the current channel table contains a concentrated channel to which the selected channel belongs, this concentrated channel is displayed with the associated channel number and spreading factor in the function field and marked red in the evaluations.



The *INVERT Q ON / OFF* softkey inverts the sign of the Q component of the signal. The default setting is *OFF*.

IEC/IEEE bus command: `:SENS:CDP:QINVert OFF`

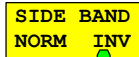

The *SIDE BAND NORM / INV* softkey chooses between measurement of the signal in a normal and an inverted spectrum.

NORM This allows measurement of base station RF signals.

INV This is practical for measurements on IF modules or components in the case of spectral inversion.

The default setting is *NORM*.

IEC/IEEE bus command: `:SENS:CDP:SBAN NORM|INV`

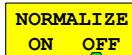

The *NORMALIZE ON / OFF* softkey eliminates the DC offset from the signal. The default setting is *OFF*.

IEC/IEEE bus command: `:[SENSe:]CDP:NORMAlize OFF`

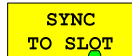

The softkey *SYNC TO SLOT* changes the phase reference from DwPCH (*OFF*) to the midamble of the selected slot (*ON*).

By default the R&S FS-K76 determines the phase reference for all downlink data slots from the downlink pilot channel (DwPCH). For e.g. beamforming or repeater measurements it might be necessary to apply different phase offsets to each time slot. Using the DwPCH as phase reference leads to rotated constellation diagrams and bad EVM values in these time slots.

By activating the new setting 'SYNC TO SLOT' the R&S FS-K76 determines the phase reference from the midamble of the selected slot. Thus the data slots can be phase rotated to each other without degrading the EVM results. The selected slot must contain at least one data channel with sufficient power for successful synchronization.

IEC-Bus-Befehl: `:SENS:CDP:STSL ON | OFF`

Frequency setting – *FREQ* key



FREQ	→	CENTER	The <i>FREQ</i> key opens a submenu for changing the measurement frequency.
CF- STEP SIZE		[]	The <i>CENTER</i> softkey opens the input window for manual entry of the center frequency. The permissible input range of the center frequency is $\text{Minspan}/2 \leq f_{\text{center}} \leq f_{\text{max}} - \text{Minspan}/2$
[]		[]	f_{center} center frequency
[]		[]	Minspan smallest selectable span > 0 Hz (10 Hz)
[]		[]	f_{max} maximum frequency
[]		[]	IEC/IEEE bus command: :FREQ:CENT 100MHz
FREQ OFFSET		[]	<i>CF STEPSIZE</i> opens a submenu for setting incrementation of the center frequency. There is an option of entering the step size manually (<i>MANUAL</i> softkey) or using the current measurement frequency (<i>CENTER</i> softkey). The softkeys are described in the manual for the basic unit.
[]		[]	IEC/IEEE bus command: :FREQ:CENT:STEP <numeric_value>
[]		[]	The <i>FREQUENCY OFFSET</i> softkey enables entry of an arithmetic frequency offset that is added to the frequency axis labelling. The range for the offset is –100 GHz to 100 GHz. The default setting is 0 Hz.
			IEC/IEEE bus command: :FREQ:OFFS 10 MHz

Span settings – *SPAN* key

The *SPAN* key is disabled for measurements in the code domain analyzer. For all other measurements (see *MEAS* key), the permissible span settings are explained for the measurement concerned. The associated menu corresponds to that of the measurement in the basic unit and is described in the manual for the basic unit.

Level settings – AMPT key

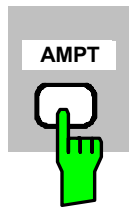

REF LEVEL	The <i>AMPT</i> key opens a submenu for setting the reference level.
ADJUST REF LEVEL	The <i>REF LEVEL</i> softkey enables entry of the reference level. The entry is in dBm.
	IEC/IEEE bus command: :DISP:WIND:TRAC:Y:RLEV -60dBm
	<i>ADJUST REF LEVEL</i> executes a routine for optimum matching of the reference level to the signal.
Y PER DIV	IEC/IEEE bus command: :SENS1:CDP:LEV:ADJ
REF VALUE POSITION	<i>Y PER DIV</i> sets the grid spacing on the Y axis for all diagrams in which this is possible.
	IEC/IEEE bus command: :DISP:WIND2:TRACe1:Y:SC:PDIV
RF ATTEN MANUAL	<i>REF VALUE POSITION</i> allows entry of the position of the Y axis reference value on the axis (0 to 100%).
RF ATTEN AUTO	IEC/IEEE bus command: :DISPlay[:WINDow<1 2>]:TRACe<1..3>:Y[:SCALE]:RPOSition
	The <i>RF ATTEN MANUAL</i> softkey activates entry of attenuation independently of reference level. The attenuation can be altered in 10 dB increments from 0 to 70 dB. Other entries are rounded to the next lowest integral. If the specified reference level can no longer be set for the given RF attenuation, it is matched and the "Limit reached" message appears.
	IEC/IEEE bus command: :INP:ATT 40 DB
	The <i>RF ATTEN AUTO</i> softkey sets the RF attenuation automatically as a function of the set reference level. This ensures that the optimum attenuation you wish is always used. <i>RF ATTEN AUTO</i> is the default setting.
	IEC/IEEE bus command: :INP:ATT:AUTO ON

Marker settings – MKR key

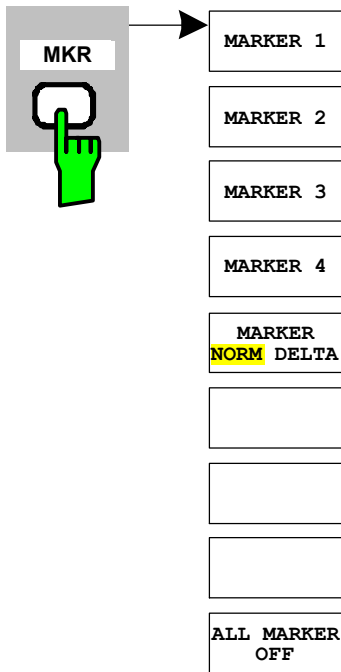

The *MARKER* key opens a submenu for the marker settings.

Markers are not available for *RESULT SUMMARY* and *CHANNEL TABLE* evaluations. Up to four markers can be activated in all other evaluations and defined as markers or delta markers with the the *MARKER NORM / DELTA* softkey.

The *MARKER 1–4* softkeys select and enable the particular marker. *MARKER 1* is always the normal marker after it is enabled, while *MARKER 2* through *4* are delta markers referred to *MARKER 1* after they are enabled. The *MARKER NORM / DELTA* softkey can be used to transform these markers into markers with absolute measured value indication. If *MARKER 1* is the active marker, *MARKER NORM / DELTA* is used to enable an additional delta marker. Press the *MARKER 1–4* softkeys again to disable the selected marker.

IEC/IEEE bus command: :CALC:MARK ON;
 :CALC:MARK:X <value>;
 :CALC:MARK:Y?
 :CALC:DELT ON;
 :CALC:DELT:MODE ABS|REL
 :CALC:DELT:X <value>;
 :CALC:DELT:X:REL?
 :CALC:DELT:Y?

The *ALL MARKER OFF* softkey disables all markers (reference and delta markers). It also disables the functions and displays associated with the markers and delta markers.

IEC/IEEE bus command: :CALC:MARK:AOFF

The parameters relating to an enabled marker are read out above the diagrams:

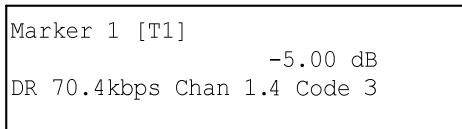
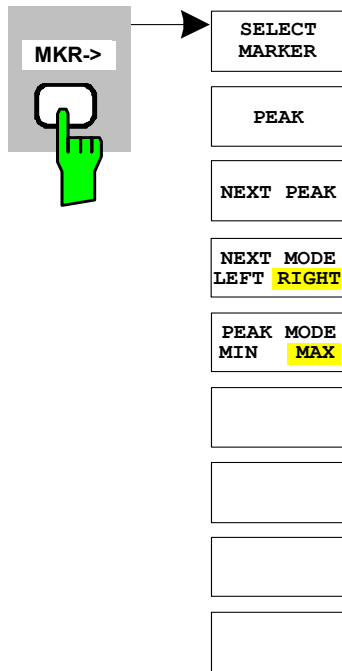

Fig. 5–27 Marker field of CDP measurement

For all other measurements not belonging to the code domain analyzer the marker functions of the basic unit apply.

Marker settings – MKR → key



The *MKR →* key opens a submenu for marker functions:

The *SELECT MARKER* softkey selects the required marker in a data entry box. If the marker is disabled, it is enabled and can then be moved. The entry is numeric. Delta marker 1 is selected by entering '0'.

IEC/IEEE bus command: :CALC:MARK1 ON;
 :CALC:MARK1:X <value>;
 :CALC:MARK1:Y?

The *PEAK* softkey sets the active marker or delta marker to the maximum/minimum of the associated trace.

If no marker was activated before opening the *MKR →* menu, marker 1 is automatically enabled and the *PEAK* function is executed.

IEC/IEEE bus command: :CALC:MARK:MAX
 :CALC:DELT:MAX
 :CALC:MARK:MIN
 :CALC:DELT:MAX

The *NEXT PEAK* softkey sets the active marker or delta marker to the next lowest maximum/minimum value of the associated trace. The search direction is specified by the setting in the *NEXT MODE LEFT / RIGHT* submenu.

IEC/IEEE bus command: :CALC:MARK:MAX:NEXT
 :CALC:DELT:MAX:NEXT
 :CALC:MARK:MIN:NEXT
 :CALC:DELT:MIN:NEXT

The *NEXT MODE LEFT / RIGHT* softkey sets the direction for searching for the next maximum/minimum value. *SEARCH NEXT LEFT / RIGHT* searches for the next signal maximum left/right from the active marker, i.e. only signal segments smaller/greater than the current marker position enter the search.

IEC/IEEE bus commands: CALC:MARK:MAX:LEFT
 CALC:DELT:MAX:LEFT
 CALC:MARK:MIN:LEFT
 CALC:DELT:MIN:LEFT
 CALC:MARK:MAX:RIGH
 CALC:DELT:MAX:RIGH
 CALC:MARK:MIN:RIGH
 CALC:DELT:MIN:RIGH

The *PEAK MODE MIN / MAX* softkey sets whether the peak search should determine the maximum or minimum value of the trace. The parameter affects the response of the *PEAK* and *NEXT PEAK* softkeys.

IEC/IEEE bus command: --

Marker functions – MKR FCTN key

The *MKR FCTN* key is disabled for all measurements of the code domain analyzer. The softkeys of the menu are described in the manual of the basic unit for all other measurements of the R&S FS-K76.

Bandwidth setting – BW key

The *BW* key is disabled for all measurements of the code domain analyzer. The softkeys associated with the menu are described in the manual of the basic unit for all other measurements of the R&S FS-K76.

Measurement control – SWEEP key

The menu of the *SWEEP* key contains options for switching between one-shot and continuous measurement and for the control of one-shot measurements. For measurements in the spectral range, the measurement time for a sweep can also be set. All softkeys associated with the menu are described in the manual of the basic unit.

Measurement selection – MEAS key

The menu of the *MEAS* key contains all the measurements that can be selected at the pressing of a key in the R&S FS-K76. The menu and its submenus are described in Chapter 5.

Trigger settings – TRIG key

The selectable trigger options depend on the measurement selected. The code domain power analyzer can work in free running mode or use an external trigger. The trigger options for all other measurements are identical to those of the corresponding measurement in the basic unit. The associated softkeys are described in the manual for the basic unit.



With the softkey *EXTERN* the external trigger source can be selected. From firmware V2.60/3.60 on also the external trigger level can be adjusted in the range from 0.5V to 3.5V. The default value is 1.4V.

IEC-Bus-command:

```
:TRIGg:SEQ:LEV:EXT <numeric_value>
```

Trace settings – TRACE key

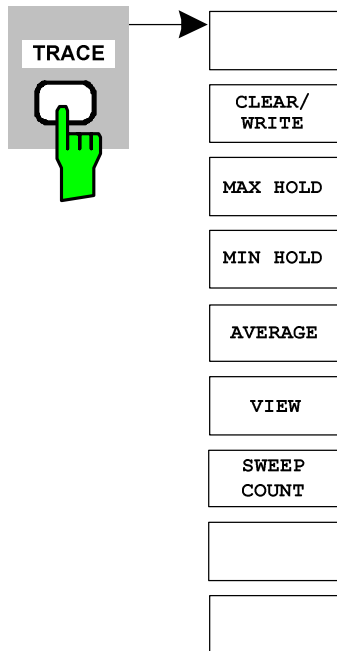

The *TRACE* key opens the following submenu:

The *CLEAR / WRITE* softkey activates overwrite mode for the acquired measured values, i.e. the trace is rewritten for each sweep. After every actuation of the *CLEAR / WRITE* softkey, the unit deletes the selected trace memory and restarts the measurement.

IEC/IEEE bus command: :DISP:WIND:TRAC:MODE WRIT

The *MAX HOLD* softkey activates the peak value detector. On every sweep, the analyzer only accepts the new measured value into the saved trace data if it is larger than the previous one. Pressing the *MAX HOLD* softkey a second time deletes the trace memory and starts peak value detection from the beginning again.

IEC/IEEE bus command: :DISP:WIND:TRAC:MODE MAXH

The *MIN HOLD* softkey activates the minimum value detector. On every sweep, the analyzer only accepts the new measured value into the saved trace data if it is smaller than the previous one. Pressing the *MIN HOLD* softkey a second time deletes the trace memory and starts minimum peak detection from the beginning again.

IEC/IEEE bus command: :DISP:WIND:TRAC:MODE MINH

The *AVERAGE* softkey enables the trace averaging function. The average is formed over several sweeps. Averaging is performed as a function of the *AVG MODE LOG / LIN* setting on the logarithmized level values or the measured power/voltage values. Averaging is restarted every time the *AVERAGE* softkey is pressed. The trace memory is always cleared.

IEC/IEEE bus command: :DISP:WIND:TRAC:MODE AVER

For measurements in the code domain analyzer, an *AVERAGE*, *MAX HOLD* or *MIN HOLD* is possible.

In channel occupancy table evaluation, the channel configuration measured on the first sweep is kept for the trace statistics.

If the signal is reconfigured, you must again press the *SINGLE SWEEP* softkey (and possibly *CONTINUOUS SWEEP*).

The evaluations *RESULT SUMMARY*, *BIT STREAM* and the *CONSTELLATION* diagrams only support *CLEAR / WRITE* mode.

The softkey *VIEW* freezes the trace.

IEC/IEEE bus command: :DISP:WIND:TRAC:MODE VIEW

The *SWEEP COUNT* softkey sets the number of sweeps used for averaging. The permissible range is 0 to 30000, though the following should be noted:

Sweep count = 0 means sliding averaging with averaging length of 10.

Sweep count = 1 means no averaging.

Sweep count > 1 means averaging over the specified number of sweeps; in a continuous sweep the averaging changes to sliding averaging once this number has been reached.

The default is sliding averaging (sweep count = 0). The number of sweeps used for averaging is always equal to the averaging length of 10 for all active traces in the selected diagram.

IEC/IEEE bus command: :SWE:COUN 64

Display lines – *LINES* key

The *LINES* key is disabled for all measurements of the code domain analyzer. The menu setting options for all other measurements are equivalent to those of the corresponding measurement in the basic unit. The respective softkeys are described in the manual for the basic unit.

Measurement screen settings – *DISP* key

The menu of the *DISP* key contains softkeys for configuring the measurement screen. The menus and softkey features are described in the manual of the basic unit.

Storing and loading unit data – *FILE* key

The *FILE* menu is the same as that of the basic unit. All softkeys are described in the manual for the basic unit.

All keys on the front panel of the unit that are not specifically mentioned are identical to those of the basic unit. The functions of the keys and the softkeys are described in the manual of the basic unit.

Preset of device – *PRESET* key

The *PRESET* key presets the device. The behaviour is the same as of the basic unit and is described in the manual for the basic unit.

Calibration of device – *CAL* key

The menu *CAL* is the same as that of the basic unit. All softkeys are described in the manual for the basic unit.

Setup of device – *SETUP* key

The menu *SETUP* is the same as that of the basic unit. All softkeys are described in the manual for the basic unit. The usage of transducer factors is possible in the Code-Domain as well as in the RF measurements.

Using the FS-K9 "Measurements with Power Sensor" is also possible within that application. Therefore the FS-K9 must be installed and the option key must be entered, then in the side menu the softkey *POWERMETER* is available. For further details of the FS-K9 please refer to the FS-K9 software manual.

Printing – *HCOPY* key

The menu *HCOPY* is the same as that of the basic unit. All softkeys are described in the manual for the basic unit.

All keys on the front panel of the unit that are not specifically mentioned are identical to those of the basic unit. The functions of the keys and the softkeys are described in the manual of the basic unit.

6 Remote Control Commands

This chapter describes the remote control commands for the application firmware.

The commands that also apply to the basic unit in *SPECTRUM* mode and the system settings are described in the operating manual for the analyzer.

CALCulate:FEED subsystem

CALCulate:FEED subsystem selects the type of evaluation for the measured data. This corresponds to the selection of the result display in manual operation.

COMMAND	PARAMETER	UNITS	REMARKS
CALCulate<1 2> :FEED:	<string>		No poll

:CALCulate<1|2>:FEED <string>

This command selects the measured data that are displayed.

Parameters: <string>::= 'XPOW:CDP' |
 'XPOW:CDP:RAT' |
 'XPOW:CDEP' |
 'XTIM:CDP:MACCuracy' |
 'XTIM:CDP:PVSLOT:ABS' |
 'XTIM:CDP:PVSLOT:RAT' |
 'XTIM:CDP:PVSymbol' |
 'XTIM:CDP:BSTream' |
 'XTIM:CDP:ERR:SUMM' |
 'XTIM:CDP:ERR:CTABLE' |
 'XTIM:CDP:ERR:PCDomain' |
 'XTIM:CDP:SYMB:CONST' |
 'XTIM:CDP:SYMB:EVM' |
 'XTIM:CDP:COMP:EVM' |
 'XTIM:CDP:COMP:CONST'

The meanings of the string parameters are as follows:

'XPOW:CDP'	Result display of code domain power (absolute) in bar graph (CALCulate<1>)
'XPOW:CDP:RAT'	Result display of code domain power ratio (relative) in bar graph (CALCulate<1>)
'XPOW:CDEP'	Result display of code domain error power in bar graph (CALCulate<1>)
'XTIM:CDP:ERR:SUMM'	Tabular display of results (CALCulate<2>)
'XTIM:CDP:ERR:CTABLE'	Display of channel occupancy table (CALCulate<1>)
'XTIM:CDP:ERR:PCDomain'	Result display of peak code domain error (CALCulate<2>)
'XTIM:CDP:MACCuracy'	Result display of composite EVM (CALCulate<2>)
'XTIM:CDP:PVSLOT:ABS'	Result display of power versus slot, absolute (CALCulate<2>)
'XTIM:CDP:PVSLOT:RAT'	Result display of power versus slot, relative (CALCulate<2>)
'XTIM:CDP:PVSymbol'	Result display of power versus symbol (CALCulate<2>)
'XTIM:CDP:BSTream'	Result display of bit stream (CALCulate<2>)
'XTIM:CDP:SYMB:CONST'	Result display of symbol constellation (CALCulate<2>)
'XTIM:CDP:SYMB:EVM'	Result display of error vector magnitude (CALCulate<2>)
'XTIM:CDP:COMP:CONST'	Result display of composite constellation (CALCulate<2>)

Example:

"INST:SEL BTDS"	'Activate TD-SCDMA BTS
"INIT:CONT OFF"	'Select single sweep
"CALC2:FEED 'XTIM:CDP:MACC'"	'Select COMP EVM evaluation
"INIT;*WAI"	'Start measurement with synchronization
"TRAC? TRACE2"	'Poll COMP EVM data

Characteristics:

*RST value:	'XPOW:CDP:RAT'	(CALCulate<1>)
	'XTIM:CDP:ERR:SUMM'	(CALCulate<2>)
SCPI:	compliant	

Note: *Code domain power measurements are always shown in split screen mode and the allocation of the evaluation to the measurement window is fixed. The necessary or allowed numerical suffix in CALCulate is therefore specified in brackets in every evaluation.*

CALCulate:LIMit: ESPectrum subsystem

CALCulate:LIMit: ESPectrum subsystem defines the limit check for spectral measurements.

COMMAND	PARAMETER	UNITS	REMARKS
CALCulate<1 2> LIMit<1...8> :ESPectrum :CHECK :X? :Y? :MODE :RESTore :VALue	AUTO MANual USER <numeric value>		Query only Query only

:CALCulate:LIMit:ESPectrum:CHECK:X?

:CALCulate:LIMit:ESPectrum:CHECK:Y?

These commands return the X-value and the Y-value respectively at the maximum overstepping of the spectrum emission mask limits.

Example: "INST BTDS" 'Switches unit to TD-SCDMA BTS
'mode
"CALC:LIM:ESP:CHECK:X?" 'Returns the frequency at the maximum overstepping

Characteristics: *RST-Wert: —
SCPI: instrument-specific

:CALCulate:LIMit:ESPectrum:MODE AUTO | MANual | USER

This command enables and disables automatic selection of the limit line in the spectrum emission mask measurement.

Parameters: AUTO The limit line sets itself according to the measured channel power.
MANUAL One of the three specified limit lines is set. The selection is made with the command CALC:LIM:ESP:VAL.
USER Poll only, user-defined limit lines are enabled (refer to the details of limit lines in the manual for the unit).

Example: "INST:SEL BTDS" 'Activate TD-SCDMA BTS
"INIT:CONT OFF" 'Select single sweep
"CONF:CDP:MEAS ESP" 'Select spectrum emission mask measurement
"CALC:LIM:ESP:MODE AUTO" 'Activates automatic selection of limit line
"INIT;*WAI" 'Start measurement with synchronization
"CALC:LIM:FAIL?" 'Poll result of limit check

Characteristics: *RST value: AUTO
SCPI: instrument-specific

:CALCulate:LIMit:ESpectrum:REStore

This command restores the standard limit lines for spectrum emission mask measurement. All changes to the standard limit lines are thus lost and they are again as when delivered.

Example:

"INST BTDS"	'Switches unit to TD-SCDMA BTS mode
"CALC:LIM:ESP:REST"	'Resets spectrum emission mask limit lines to default

Characteristics: *RST value: SCPI: instrument-specific

This command is an event, so it has neither a poll nor an *RST value.

:CALCulate:LIMit:ESALuePectrum:VALue <numeric_value>

This command switches to manual limit line selection. The limit line is selected by specifying the expected power as a value. One of the three possible limit lines is selected depending on the value entered:

Entered value in dBm	Selected limit line	Value when polled
Value ≥ 34	"P ≥ 34 "	34
$26 \leq$ Value < 34	"26 \leq P < 34 "	26
Wert < 26	"P < 26 "	0

Example:

"INST:SEL BTDS"	'Activate TD-SCDMA BTS
"INIT:CONT OFF"	'Select single sweep
"CONF:CDP:MEAS ESP"	'Select spectrum emission mask measurement
"CALC:LIM:ESP:VALue 34"	'Activates manual selection of limit line and selects one for P ≥ 34
"INIT;*WAI"	'Start measurement with synchronization
"CALC:LIM:FAIL?"	'Poll result of limit check

Characteristics: *RST value: 0
SCPI: instrument-specific

CALCulate:MARKer subsystem

COMMAND	PARAMETER	UNITS	REMARKS
CALCulate<1 2> :MARKer<1...4> :FUNction :CDPower [:BTS] :RESult? :POWer :MODE	SLOT PDATa PD1 PD2 PMIDamble RHO MACCuracy PCDerror FERRor CERRor TFRame IQOFFset IQIMbalance ACTive SRATe CHANnel SFACtor CDPabsolute CDPRelative EVMRms EVMPeak WRITe MAXHold		Poll only

:CALCulate<1|2>:MARKer<1>:FUNction:CDPower[:BTS]:RESult?

SLOT | PDATa | PD1 | PD2 | PMIDamble | RHO | MACCuracy | PCDerror |
FERRor | CERRor | TFRame | IQOFFset | IQIMbalance | ACTive | SRATe |
CHANnel | SFACtor | CDPabsolute | CDPRelative | EVMRms | EVMPeak

This command polls the measured and calculated values of code domain power analysis. The results are provided for the channel to which the code selected by the `CDPower:CODE` command belongs.

Parameters:

Global results of selected slot:

SLOT	Slot number		
PDATa	Power data fields in dBm	FERRor	Frequency error in Hz
PD1	Power data field 1 in dBm	CERRor	Chip rate error in ppm
PD2	Power data field 2 in dBm	TFRame	Trigger to frame
PMIDamble	Power midamble in dBm	IQIMbalance	IQ imbalance in %
RHO	RHO	IQOFFset	IQ offset in %
MACCuracy	Composite EVM in %	ACTive	Number of active channels
PCDerror	Peak code domain error in dB		

Channel results:

SRATe	Data rate in kbps
CHANnel	Channel number
SFACtor	Spreading factor of channel
CDPRelative	Channel power relative in dB
CDPabsolute	Channel power absolute in dBm
EVMRms	Error vector magnitude RMS in %
EVMPeak	Error vector magnitude Peak in %

Note: The trigger to frame (*TFRame*) value produces a "9" if the trigger is set to FREE RUN.

Example:	"INST:SEL BTDS"	'Activate TD-SCDMA BTS meaning
		'CDP relative on screen A and
		'Result Summary active on screen B
	"INIT:CONT OFF"	'Select single sweep
	"INIT;*WAI"	'Start measurement with
		synchronization
	"CALC:MARK:FUNC:CDP:RES? PDAT"	'Read out power of data fields
	"CDP:SLOT 5"	'Selects slot 5
	"CDP:CODE 11"	'Select code number 11
	"CALC:MARK:FUNC:CDP:RES? EVMR"	'Read out EVM RMS of code with
		'number 11 in slot 5

Characteristics: *RST value: –
SCPI: instrument-specific

:CALCulate<1|2>:MARKer<1...4>:FUNCtion:POWer:MODE WRITe | MAXHold

This command selects the Clear Write or Maxhold for Channel Power values.

Example: "CALC:MARK:FUNC:POW:MODE MAXH" 'Maxhold für Channel Power Werte

Characteristics: *RST value: WRITe
SCPI: instrument-specific

CALCulate:PEAKsearch | PSEarch subsystem

CALCulate<1|2>:PEAKsearch|PSEarch:AUTO ON | OFF

By using this command, the peak list in the spurious measurement is calculated automatically after a measurement. For each range, exactly one peak value is calculated.

The SENSE suffix is unused.

Example: "CALC:PEAK:AUTO ON" Switches the automatic peak search on

Characteristics: *RST value: OFF
SCPI: instrument-specific

CONFigure:CDPower subsystem

This subsystem contains the commands for selecting and configuring measurements in the TD-SCDMA application firmware. Only the numeric suffix 1 is allowed for CONFigure. You will find further settings for code domain power analysis under the :[SENSe]:CDPower command. Further settings for spectrum emission mask measurement can be found under the CALCulate:LIMit:ESpectrum command.

BEFEHL	PARAMETER	EINHEIT	KOMMENTAR
CONFigure :CDPower [:BTS]			
:CTABLE :CATalog? :COMMent :COPY :DATA :DELeTe :MSHift :NAME :ORDer :SELeCt [:STATe] :MEASurement :PVTime :HDYNamic :SFRames :SPOint	<string> <file_name> <numeric_value>, <numeric_value>, <numeric_value>, <numeric_value>, <numeric_value>, <numeric_value>, <numeric_value> <numeric_value> <file_name> CODE MIDamble <file_name> <Boolean> POWER ACLR ESpectrum OBANdwidth OBWidth PVTime CDPower CCDF MCAClr <Boolean> <numeric_value> <numeric_value>		

:CONFigure:CDPower[:BTS]:CTABLE:CATalog?

This command polls the names of all channel tables saved on harddisk for TD-SCDMA BTS.

The syntax of the output format is as follows:

<Sum of sizes of all subsequent files>,<Spare capacity on harddisk>,
<1st file name>,<1st file size>,<2nd file name>,,<2nd file size>,,...,<nth file name>,,
<nth file size>,,

Example: "INST:SEL BTDS" 'Activate TD-SCDMA BTS
 "CONF:CDP:CTAB:CAT?" 'Poll catalog

Characteristics: *RST value: —
SCPI: instrument-specific

:CONFigure:CDPower[:BTS]:CTABLE:COMMent <string>

This command defines a comment on the selected channel table.
Before using this command, you must set the name of the channel table using the
CONF:CDP:CTAB:NAME command and enter a valid channel table by CONF:CDP:CTAB:DATA.

Example: "INST:SEL BTDS" 'Activate TD-SCDMA BTS
 "CONF:CDP:CTAB:NAME 'NEW_TAB'" 'Select table to edit
 "CONF:CDP:CTAB:COMM 'Comment for NEW_TAB'"

Characteristics: *RST value: ""
SCPI: instrument-specific

:CONFigure:CDPower[:BTS]:CTABLE:COPY <file_name>

This command copies one channel table to another. You select the channel table you want to copy by the `CONF:CDP:CTAB:NAME` command.

Parameters: <file_name> ::= name of new channel table

Example: `"INST:SEL BTDS"` 'Activate TD-SCDMA BTS
`"CONF:CDP:CTAB:NAME 'CTAB_1'"` 'Select table to edit
`"CONF:CDP:CTAB:COPY 'CTAB_2'"` 'Copies CTAB_1 to C_TAB2

Characteristics: *RST value: —
 SCPI: instrument-specific

The name of the channel table may consist of up to eight characters. This command is an event, so it has neither an *RST value nor a poll function.

:CONFigure:CDPower[:BTS]:CTABLE:DATA 1..6, 0..4, 1..16, 0..2, 1..16, 0 | 1, 0, 0...

This command defines a channel table. The whole table is defined in one operation. The inactive channels (INACTIVE) do not have to be defined. Eight values are specified for a line of a table.

< Channel type >, <Code class>, <Code number>, <Modulation type>, <Midamble shift>, <Status>, <Reserved 1>, <Reserved 2>,

Channel type: The channel type is coded with numbers as follows:
 1 = Midamble
 2 = DPCH
 3 = P-CCPCH
 4 = S-CCPCH
 5 = FPACH
 6 = PRACH

Code class: 0-4
 Code number: 1-16
 Modulation type: 0 = invalid (for midamble)
 1 = QPSK
 2 = 8PSK

Midamble shift: 1-16
 Status: 0: inactive, 1: active
 Can be used in a setting command to disable a channel temporarily.

Reserved 1: Always 0, reserved for additions
 Reserved 2: Always 0, reserved for additions

Before using this command, you must set the name of the channel table using the `CONF:CDP:CTAB:NAME` command.

Example: `"INST:SEL BTDS"` 'Activate TD-SCDMA BTS
`"CONF:CDP:CTAB:NAME 'NEW_TAB'"` 'Select table to edit
`"CONF:CDP:CTAB:DATA 2,4,1,1,1,1,0,0,`
`2,4,2,1,1,1,0,0"` 'Defines two data channels with QPSK
 'modulation

Characteristics: *RST value: —
 SCPI: instrument-specific

:CONFigure:CDPower[:BTS]:CTABLE:DELeTe

This command deletes the selected channel table. You select the channel table you want to delete by the `CONF:CDP:CTAB:NAME` command.

Example:

```
"INST:SEL BTDS"           'Activate TD-SCDMA BTS
"CONF:CDP:CTAB:NAME 'CTAB_2'" 'Select table to edit
"CONF:CDP:CTAB:DEL"       'Deletes CTAB_2
```

Characteristics: *RST value: —
SCPI: instrument-specific

This command is an event, so it has neither an *RST value nor a poll function.

CONFigure<1>:CDPower[:BTS]:MEASurement POWER | ACLR | ESpectrum | OBANdwith | OBWidth | CDPower | CCDF

This command selects the measurement of the Application Firmware R&S FS-K76, TD-SCDMA base station test. The predefined settings of the different measurements are described in Chapter 6.

Parameters:

POWER	Channel power measurement (TD-SCDMA forward standard) with predefined settings
ACLR	Adjacent channel power measurement (TD-SCDMA forward standard) with predefined settings
ESpectrum	Check of signal power (spectrum emission mask)
OBANdwith OBWidth	Measurement of occupied bandwidth
PVTime	Measurement of power versus time
CDPower	Code domain analyzer measurement
CCDF	Signal statistic measurements
MCAClr	Multi Carrier Adjacent Channel Leakage Power Ratio

Example:

```
"INST:SEL BTDS"           'Activate TD-SCDMA BTS
"INIT:CONT OFF"          'Select single sweep
"CONF:CDP:MEAS POW"      'Select channel power measurement
"INIT;*WAI"              'Start measurement with
                           'synchronization
```

Characteristics: *RST value: CDPower
SCPI: instrument-specific

:CONFigure:CDPower[:BTS]:CTABLE:MSHift 2 | 4 | 6 | 8 | 10 | 12 | 14 | 16

This command defines the maximum number of midamble shifts in the channel table.

Example:

```
"INST:SEL BTDS"           'TD-SCDMA BTS aktivieren
"CONF:CDP:CTAB:NAME 'NEW_TAB'" 'Tabelle zum Bearbeiten wählen
"CONF:CDP:CTAB:MSHift 14"   '14 Midamble-Shifts zulassen
```

Characteristics: *RST-Wert: 16
SCPI: instrument-specific

:CONFigure:CDPower[:BTS]:CTABLE:NAME <file_name>

This command selects a channel table to edit or create. It is *not* used for analysis. In this context, see commands `CONF:CDP:CTAB:STAT` and `CONF:CDP:CTAB:SEL`.

Example:

```
"INST:SEL BTDS"           'Activate TD-SCDMA BTS
"CONF:CDP:CTAB:NAME 'NEW_TAB'" 'Select table to edit
```

Characteristics: *RST value: ""
SCPI: instrument-specific

:CONFigure<1>:CDPower[:BTS]:CTABLE:ORDER CODE | MIDamble

This command selects sorting of the channel table in code order or midamble order.

Characteristics: *RST value: CODE
SCPI: instrument-specific

:CONFigure<1>:CDPower[:BTS]:CTABLE:SElect <string>

This command selects a predefined channel table file. Before using this command, you must have enabled the *RECENT* channel table by the `CONF:CDP:CTAB ON` command.

Example:

"INST:SEL BTDS"	'Activate TD-SCDMA BTS meaning 'CDP relative on screen A and 'Result Summary active on screen B
"INIT:CONT OFF"	'Select single sweep
"INIT;*WAI"	'Start measurement with 'synchronization
"CONF:CDP:CTAB ON"	'so that channel table can be enabled
"CONF:CDP:CTAB:SEL 'CTAB_1'"	'Use predefined channel table
"INIT;*WAI"	'Select channel table 'Start measurement with 'synchronization

Characteristics: *RST value: "RECENT"
SCPI: instrument-specific

:CONFigure<1>:CDPower[:BTS]:CTABLE[:STATe] ON | OFF

This command enables and disables the channel table. Enabling results in the measured channel table being saved as *RECENT* and enabled. After the *RECENT* channel table is enabled, another channel table can be selected with the `CONF:CDP:CTABLE:SElect` command.

Note: You must always enable the *RECENT* channel table first with the `CONF:CDP:CTAB:STAT` command and then use the `CONF:CDP:CTAB:SElect` command to select the channel table you require.

Example:

"INST:SEL BTDS"	'Activate TD-SCDMA BTS meaning 'CDP relative on screen A and 'Result Summary active on screen B
"INIT:CONT OFF"	'Select single sweep
"INIT;*WAI"	'Start measurement with 'synchronization
"CONF:CDP:CTAB ON"	'so that channel table can be enabled
"CONF:CDP:CTAB:SEL 'CTAB_1'"	'Use predefined channel table
"INIT;*WAI"	'Select channel table 'Start measurement with 'synchronization

Characteristics: *RST value: OFF
SCPI: instrument-specific

:CONFigure:CDPower:BTS:PVTime:HDYNamic ON|OFF

This command selects the high dynamic mode. The sweep mode is automatically set to single sweep.

Example:

"INST:SEL BTDS"	'Activate TD-SCDMA BTSg
"CONF:CDP:MEAS PVT"	'Select Power Vs Time
"CONF:CDP:PVT:HDYN ON"	'Switch on high dynamic

Characteristics: *RST-Wert: OFF
SCPI: instrument-specific

:CONFigure:CDPower[:BTS]:PVTime:SFRames

This command defines the number of subframes for averaging..

Example:

"INST:SEL BTDS"	'Activate TD-SCDMA BTS
"CONF:CDP:MEAS PVT"	'Select Power Vs Time
"CONF:CDP:PVT:SFR 50"	'Set number of subframes

Characteristics: *RST value: 100
SCPI: instrument-specific

:CONFigure:CDPower[:BTS]:PVTime:SPOint 1...7

This command sets the switching point between uplink and downlink slots..

Example:

"INST:SEL BTDS"	'Activate TD-SCDMA BTS
"CONF:CDP:MEAS PVT"	'Select Power Vs Time
"CONF:CDP:PVT:SPO 6"	'Set switching point

Characteristics: *RST value: 3
SCPI: instrument-specific

INSTrument subsystem

The INSTrument subsystem selects the operating mode of the unit either by text parameters or by permanently assigned numbers.

COMMAND	PARAMETER	UNITS	REMARKS
INSTrument :NSElect [:SElect]	<numeric_value> SANalyzer BTDScdma		

:INSTrument:NSElect 1 | 17

This command toggles between the operating modes by numbers.

Parameters: 1: spectral analysis mode
17: TD-SCDMA FWD (BTS) mode

Example: "INST:NSEL 17" 'Activate TD-SCDMA BTS

Characteristics: *RST value: 1
SCPI: compliant

:INSTrument[:SElect] SANalyzer | BTDScdma

This command toggles between the operating modes by text parameters.

TD-SCDMA BTS (BTDS) sets the unit to a defined status. The preset values are explained in Chapter 2, section "Basic settings in TD-SCDMA BTS mode".

Example: "INST BTDS" 'Activate TD-SCDMA BTS

Characteristics: *RST value: SANalyzer
SCPI: compliant

SENSe:CDPower subsystem

This subsystem sets the parameters for code domain measurement mode. The numeric suffix for SENSE<1|2> is meaningless for this subsystem.

COMMAND	PARAMETER	UNITS	REMARKS
[SENSe<1 2>] :CDPower :CODE :ICTReshold :IQLength :LEVel :ADJust :MSHift :NORMalize :QINVert :SBANd :SCODE :SET :COUNT [:VALue] :SLOT :STANdard :STSLot	<numeric_value> <numeric_value> <numeric_value> <numeric_value> ON OFF ON OFF NORMAl INVerse <numeric_value> <numeric_value> <numeric_value> <numeric_value> GPP TSM OFF <numeric_value> <Boolean>	DB	

:[SENSe<1|2>]:CDPower:CODE 1..16

This command selects the code number.

Example: "INST:SEL BTDS" 'Activate TD-SCDMA BTS meaning
'CDP relative on screen A and
"INIT:CONT OFF" 'Result Summary active on screen B
"CDP:CODE 11" 'Select single sweep
"INIT;*WAI" 'Select code number 11
'Start measurement with synchronization

Characteristics: *RST value: 0
SCPI: instrument-specific

:[SENSe]:CDPower:ICTReshold -100 dB ...0 dB

This command sets the threshold above which a channel is regarded as active. The level refers to total signal power.

Example: "INST:SEL BTDS" 'Activate TD-SCDMA BTS meaning
'CDP relative on screen A and
"INIT:CONT OFF" 'Result Summary active on screen B
"CDP:ICTR -10DB" 'Select single sweep
"INIT;*WAI" 'Threshold on -10 dB
'Start measurement with
'synchronization

Characteristics: *RST value: -40 dB
SCPI: instrument-specific

:[SENSe:]CDPower:IQLength 2...63

This command sets the IQ capture length in multiples of slots. The range is from 2 to 63.

Example:

"INST:SEL BTDS"	'Activate TD–SCDMA BTS meaning
	'CDP relative on screen A and
	'Result Summary active on screen B
"INIT:CONT OFF"	'Select single sweep
"CDP:IQL 8"	'8 slots capture length
"INIT;*WAI"	'Start measurement with synchronization

Characteristics: *RST value: 7
SCPI: instrument–specific

:[SENSe:]CDPower:LEVel:ADJust

This command initiates automatic setting of the RF attenuation and IF gain to the level of the applied signal. The unit is put into *RF ATTEN MANUAL* mode to optimize RF attenuation and IF gain independently of each other. This mode is retained after changing from TD–SCDMA BTS mode to *SPECTRUM* mode. The query of that command (*CDP:LEV:ADJ?*) returns **PASSED** on successful level adjustment or **FAILED** if no optimum settings could be found.

Example:

"INST:SEL BTDS"	'Activate TD–SCDMA BTS meaning
	'CDP relative on screen A and
	'Result Summary active on screen B
"INIT:CONT OFF"	'Select single sweep
"CDP:LEV:ADJ"	'Start automatic level setting
"INIT;*WAI"	'Start measurement with synchronization

Characteristics: *RST value: –
SCPI: instrument–specific

This command is an event, so it has neither an *RST value nor a poll function.

:[SENSe:]CDPower:MSHift 2 | 4 | 6 | 8 | 10 | 12 | 14 | 16

This command sets the maximum number of midamble shifts

Example:

"INST:SEL BTDS"	'Activate TD–SCDMA BTS
"CDP:MSH 10"	'Maximum midamble shift of 10

Characteristics: *RST value: 16
SCPI: instrument–specific

:[SENSe:]CDPower:NORMalize ON | OFF

This command enables and disables elimination of the IQ offset.

Example:

"INST:SEL BTDS"	'Activate TD–SCDMA BTS meaning
	'CDP relative on screen A and
	'Result Summary active on screen B
"INIT:CONT OFF"	'Select single sweep
"CDP:NORM OFF"	'Elimination of IQ offset disabled
"INIT;*WAI"	'Start measurement with synchronization

Characteristics: *RST value: OFF
SCPI: instrument–specific

:[SENSe:]CDPower:QINVert ON | OFF

This command inverts the sign of the signal Q component.

Example: "INST:SEL BTDS" 'Activate TD–SCDMA BTS meaning
"INIT:CONT OFF" 'CDP relative on screen A and
"CDP:QINV ON" 'Result Summary active on screen B
"INIT;*WAI" 'Select single sweep
'Enable invert Q component
'Start measurement with
'synchronization

Characteristics: *RST value: OFF
SCPI: instrument–specific

:[SENSe:]CDPower:SBANd NORMal | INVert

This command is used to switch the left and right sideband.

Example: "INST:SEL BTDS" 'Activate TD–SCDMA BTS meaning
"INIT:CONT OFF" 'CDP relative on screen A and
"CDP:SBAN INV" 'Result Summary active on screen B
"INIT;*WAI" 'Select single sweep
'Swap sidebands
'Start measurement with
'synchronization

Characteristics: *RST value: NORM
SCPI: instrument–specific

:[SENSe:]CDPower:SCODE 0...127

This command sets the scrambling code of the base station.

Example: "INST:SEL BTDS" 'Activate TD–SCDMA BTS meaning
"INIT:CONT OFF" 'CDP relative on screen A and
"CDP:SCOD 51" 'Result Summary active on screen B
"INIT;*WAI" 'Select single sweep
'Set scrambling code
'Start measurement with synchronization

Characteristics: *RST value: 0
SCPI: instrument–specific

:[SENSe:]CDPower:SET:COUNT 1 ... 190

If the SET COUNT is set to 1 (default value), the device behaves as normal and with the command CDPower:IQLength (IQ–Capture–Length) the number of slots can be set.

For R&S FSQ the SET COUNT can be adjusted in the range of 1...190. Is the SET COUNT greater than 1 the IQ–Capture–Length will be implicitly set to 63 slots and become unavailable. The SET COUNT defines then how many SETS of 63 slots shall be captured consecutively into the IQ RAM of the R&S FSQ.

This command is only available on R&S FSQ.

Example: "INST:SEL BTDS" 'Activate TD–SCDMA BTS meaning
"INIT:CONT OFF" 'CDP relative on screen A and
'result summary active on screen B
'Select single sweep

```

"CDP:SET:COUN 12"
"INIT;*WAI"
"CDP:SET 2"
"TRAC? TRACE1"

```

Characteristics: *RST value: 1
SCPI: device-specific

'Select 12 Sets of 63 slots on
'R&S FSQ
'Start measurement with
'synchronization
'Select results from SET 2
'Read out CDP

:[SENSe:]CDPower:SET[:VALue] 0 ... (SET COUNT-1)

With this command the SET is selected for which the results are evaluated. . Beforehand with CDP:SET:COUN a SET COUNT value greater than 1 must be set.

This command is only available on R&S FSQ.

Example:

```

"INST:SEL BTDS"
"INIT:CONT OFF"
"CDP:SET:COUN 12"
"INIT;*WAI"
"CDP:SET 2"
"TRAC? TRACE1"

```

Characteristics: *RST value: 0
SCPI: device-specific

'Activate TD-SCDMA BTS meaning
'CDP relative on screen A and
'result summary active on screen B
'Select single sweep
'Select 12 Sets of 63 slots on
'R&S FSQ
'Start measurement with
'synchronization
'Select results from SET 2
'Read out CDP

:[SENSe:]CDPower:SLOT 0 ...IQLength-1

The command selects the slot.

Example:

```

"INST:SEL BTDS"
"INIT:CONT OFF"
"CDP:SLOT 4"
"INIT;*WAI"

```

Characteristics: *RST value: 0
SCPI: instrument-specific

'Activate TD-SCDMA BTS meaning
'CDP relative on screen A and
'Result Summary active on screen B
'Select single sweep
'Selects slot 4
'Start measurement with synchronization

:[SENSe:]CDPower:STANdard GPP | TSM

This command switches between the standard 3GPP and TSM. At the moment, this affects the spectrum emission mask measurement only.

Example:

```

"INST:SEL BTDS"
"INIT:CONT OFF"
"CDP:STAN TSM"
"INIT;*WAI"

```

Characteristics: *RST value: GPP
SCPI: instrument-specific

'Activate TD-SCDMA BTS meaning
'CDP relative on screen A and
'Result Summary active on screen B
'Select single sweep
'Set TSM mode
'Start measurement with
synchronization

:[SENSe<1|2>:]CDPower:STSLot ON | OFF

This command selects the phase reference to be used.

By default the R&S FS-K76 determines the phase reference for all downlink data slots from the downlink pilot channel (DwPCH). For e.g. beamforming or repeater measurements it might be necessary to apply different phase offsets to each time slot. Using the DwPCH as phase reference leads to rotated constellation diagrams and bad EVM values in these time slots.

By activating the new setting 'SYNC TO SLOT' the R&S FS-K76 determines the phase reference from the midamble of the selected slot. Thus the data slots can be phase rotated to each other without degrading the EVM results. The selected slot must contain at least one data channel with sufficient power for successful synchronization.

Example: "SENS:CDP:STSL ON" 'Use selected slot as phase reference

Characteristics: *RST value: OFF
SCPI: instrument-specific

[SENSe<1|2>:]POWer:ACHannel:BANDwidth|BWIDth:ACHannel 100 Hz ... 1000 MHz

This command defines the channel bandwidth of the adjacent channel of the radio transmission system. If the bandwidth of the adjacent channel is changed, the bandwidths of all alternate adjacent channels are automatically set to the same value.

Example: "POW:ACH:BWID:ACH 30kHz" 'Sets the bandwidth of all adjacent channels to '30 kHz.

Characteristics: *RST value: 14 kHz
SCPI: instrument-specific

[SENSe<1|2>:]POWer:ACHannel:BANDwidth|BWIDth:ALTErnate<1...11> 100 Hz ... 1000 MHz

This command defines the channel bandwidth of the alternate adjacent channels of the radio transmission system. If the channel bandwidth of an alternate adjacent channel (e.g. channel no. 1) is changed, the bandwidth of all the following alternate adjacent channels (e.g. channels no. 2 to 11) is automatically set to the same value.

Example: "POW:ACH:BWID:ALT 30kHz" 'Sets the bandwidth of all alternate adjacent channels to 30 kHz.

"POW:ACH:BWID:ALT2 60kHz" 'Sets the bandwidth of all alternate adjacent channel 2 and the following to 60 kHz.

Characteristics: *RST value: 14 kHz
SCPI: instrument-specific

[SENSe<1|2>:]POWer:ACHannel:BANDwidth|BWIDth[:CHANnel] 100 Hz ... 1000 MHz

This command sets the channel bandwidth of the radio communication system. The bandwidths of adjacent channels are not influenced by this modification (in contrast to the FSE family).

Example: "POW:ACH:BWID 30kHz" 'Sets the bandwidth of the TX channel to '30 kHz.

Characteristics: *RST value: 14 kHz
SCPI: instrument-specific

[SENSe<1|2>:]POWer:ACHannel:MODE ABSolute | RELative

This command toggles between absolute and relative adjacent channel measurement.

Example: "SENS:POW:ACH:MODE REL" 'Swicht-on the relative measurement

Characteristics: *RST-Wert: ABS
SCPI: instrument-specific

[SENSe<1|2>:]POWer:ACHannel:PRESet ACPower | CPOWer | MCACpower | OBANdwidth | OBWidth | CN | CN0

This command adjusts the frequency span, the measurement bandwidths and the detector as required for the number of channels, the channel bandwidths and the channel spacings selected in the active power measurement. If necessary, adjacent-channel power measurement is switched on prior to the adjustment.

To obtain valid results, a complete sweep with synchronization to the end of the sweep must be performed after the adjustment. Synchronization is possible only in the single-sweep mode.

The result is queried with the command `CALCulate:MARKer:FUNCTion:POWer:RESult?`.

The command is available only for measurements in the frequency domain (span > 0).

Example: "`SENS:POW:ACH:PRES ACP`" Sets the frequency span, the measurement bandwidths and the detector as required for the ACP measurement in screen A.

Characteristics: *RST value: -
 SCPI: instrument-specific

[SENSe<1|2>:]POWer:ACHannel:PRESet:RLEVel

This command adapts the reference level to the measured channel power.

Note: Subsequent commands have to be synchronized with `*WAI`, `*OPC` or `*OPC?` to the end of the autorange process which would otherwise be aborted.

Example: "`:POW:ACH:PRES:RLEV;*WAI`" 'adapts the reference level to the measured channel power.'

Characteristics: *RST value: -
 SCPI: instrument-specific

[SENSe<1|2>:]POWer:ACHannel:PRESet:RLEVel?

This command returns **PASSED** on successful level adjustment or **FAILED** if no optimum settings could be found.

Example: "`:POW:ACH:PRES:RLEV?`" 'returns PASSED or FAILED'

Characteristics: *RST value: -
 SCPI: instrument-specific

[SENSe<1|2>:]POWer:ACHannel:REFeRence:TXCHannel:AUTO MINimum|MAXimum|LHIGhest|OFF

This command activates the automatic selection of a transmission channel to be used as a reference channel in relative adjacent-channel power measurements.

The transmission channel with the highest power, the transmission channel with the lowest power, or the transmission channel nearest to the adjacent channels can be defined as a reference channel.

MINimum: Transmission channel with the lowest power

MAXimum: Transmission channel with the highest power

LHIGhest: Lowermost transmission channel for the lower adjacent channels, uppermost transmission channel for the upper adjacent channels

OFF: deactivated the automatic selection of a transmission channel.

Example: "SENS:POW:ACH:REF:TXCH:AUTO MAX" 'The transmission channel with the highest power is used as a reference channel.'

Characteristics: *RST value: OFF
SCPI: instrument-specific

[SENSe<1|2>:]POWer:ACHannel:REference:TXCHannel:MANual 1 ... 12

Dieser Befehl legt ein Referenzkanal für die Berechnung der relativen Nachbarkanalleistungen fest.

Example: "SENS:POW:ACH:REF:TXCH:MAN 2" 'Transmission channel 2 is used as a reference.'

Characteristics: **RST value: 1
SCPI: instrument-specific

[SENSe<1|2>:]POWer:ACHannel:SLOT:START 1 ... 7

This command allows entry of the start slot for gated sweep mode. The gated mode is on between *START SLOT* and *STOP SLOT*.

Example: ":POW:ACH:SLOT:STAR 3" 'set slot 3 as start slot

Characteristics: *RST value: 4
SCPI: instrument-specific

[SENSe<1|2>:]POWer:ACHannel:SLOT:STOP 1 ... 7

This command allows entry of the stop slot for gated sweep mode. The gated mode is on between *START SLOT* and *STOP SLOT*.

Example: ":POW:ACH:SLOT:STOP 3" 'set slot 3 as stop slot

Characteristics: *RST value: 6
SCPI: instrument-specific

[SENSe<1|2>:]POWer:ACHannel:SPACing[:ACHannel] 100 Hz ... 2000 MHz

This command defines the channel spacing of the adjacent channel to the TX channel. At the same time, the spacing of alternate adjacent channels 1 to 11 is set to the double or triple etc. of the entered value.

Example: "POW:ACH:SPAC:ACH 33kHz" 'Sets the spacing between the carrier signal
'and
'- the adjacent channel to 33 kHz
'- the alternate adjacent channel 1 to 66 kHz
'- the alternate adjacent channel 2 to 99 kHz

Characteristics: *RST value: 14 kHz
SCPI: instrument-specific

[SENSe<1|2>:]POWer:ACHannel:SPACing:ALTErnate<1...11> 100 Hz ... 2000 MHz

This command defines the spacing between the alternate adjacent channels and the TX channel. If the spacing to an alternate adjacent channel ALTErnate<k> is modified, the spacing to all the following alternate adjacent channels ALTErnate<n> is set to $(<n> + 1) / (<k> + 1)$ times the entered value.

Example: "POW:ACH:SPAC:ALT1 33kHz" Sets the spacing between TX channel and 'alternate adjacent channel 1 to 100 kHz and 'between TX channel and alternate adjacent 'channel 2 to 150 kHz.

Characteristics: *RST value: 40 kHz (ALT1)
60 kHz (ALT2)
80 kHz (ALT3)
100 kHz (ALT4)
120 kHz (ALT5)
140 kHz (ALT6)
160 kHz (ALT7)
180 kHz (ALT8)
200 kHz (ALT9)
220 kHz (ALT10)
240 kHz (ALT11)
SCPI: instrument-specific

[SENSe<1|2>:]POWer:ACHannel:SPACing:CHANnel<1..11> 100 Hz ... 2000 MHz

This command defines the channel spacing of the carriers. At the same time the spacing of carriers with higher channel number are set to the same value. If the spacing is equal between all carriers it is sufficient to set the spacing between carrier 1 and 2 with the command

SENS:POW:ACP:SPAC:CHAN1 or SENS:POW:ACP:SPAC:CHAN. If the spacing are set in ascending order individual spacing of the carriers can be set.

Example: "POW:ACH:SPAC:CHAN2 25kHz" 'Sets the spacing between all carriers to 25 kHz

Characteristics: *RST value: 20 kHz
SCPI: instrument-specific

[SENSe<1|2>:]POWer:ACHannel:TXChannel:COUNT 1 ...12

This command select the entry of the number of carrier signals to be considered.

Example: ":SENS:POW:ACH:TXCH:COUN 4"

Characteristics: *RST value: 4
SCPI: instrument-specific

[SENSe<1|2>:]POWer:NCORrection ON | OFF

Dieser Befehl schaltet die Korrektur des Eigenrauschens des Gerätes bei Kanalleistungsmessung ein bzw. aus. Beim Einschalten der Funktion wird zunächst eine Referenzmessung des Eigenrauschens des Gerätes vorgenommen. Die gemessene Rauschleistung wird anschließend von der Leistung im betrachteten Kanal subtrahiert.

Bei jeder Veränderung von Mittenfrequenz, Auflösungsbreite, Sweepzeit und PegelEinstellung wird die Korrektur abgeschaltet.

Example: "POW:NCOR ON" 'Schaltet die Korrektur des Eigenrauschens ein

Characteristics: *RST value: OFF
SCPI: instrument-specific

TRACe subsystem

:TRACe[:DATA] TRACE1 | TRACE2

This command transfers trace data from the controller to the unit, the poll command reads trace data from the unit.

TRACE1, TRACE2, etc can be read out, depending on the display.

The trace data (TRACE1 | TRACE2) are formatted as follows for the different displays:

CODE DOMAIN POWER ABSOLUTE / CODE DOMAIN POWER RELATIVE (TRACE1)

The following is output for each channel:

Code class	Code class of channel, values between 0 and 4
Code number	Code number of channel, values between 1 and 16
Level	– For <i>CODE POWER ABS</i> in dBm – For <i>CODE POWER REL</i> in dB
Power detection	0 – inactive channel 1 – active channel

Thus four values are transferred for all channels:

<Code class>, <Code number>, <Level>, <Power detection>

A maximum of 16 channels are read out, channels belonging together are read out as one channel.

Example:

The example shows the results of the poll for three active channels with the following configuration:

DPCH	1.16	(CC 4)	-7.0 dB
DPCH	2.8	(CC 3)	-7.3 dB
DPCH	3.4	(CC 2)	-8.0 dB

"INST:SEL BTDS"	'Activate TD-SCDMA BTS meaning 'CDP relative on screen A and 'Result Summary active on screen B
"INIT:CONT OFF"	'Select single sweep
"INIT;*WAI"	'Start measurement with 'synchronization
"TRAC? TRACE1"	'Read out CDP relative

4,	1,	-7.0,	1,
4,	2,	-55.1,	0,
3,	2,	-7.3,	1,
4,	5,	-56.3,	0,
4,	6,	-55.8,	0,
4,	7,	-57.0,	0,
4,	8,	-56.7,	0,
2,	3,	-8.0,	1,
4,	13,	-55.8,	0,
4,	14,	-56.3,	0,
4,	15,	-55.9,	0,
4,	16,	-57.3,	0,

CODE DOMAIN ERROR POWER (TRACE1)

The following is output for each channel:

Code class	Code class of channel, values between 0 and 4
Code number	Code number of channel, values between 1 and 16
Error power	in dB
Power detection	0 – inactive channel 1 – active channel

Thus four values are transferred for all channels:

<Code class>, <Code number>, <Level>, <Power detection>

An error power is output for the CDEP, so consolidation of the power values is not meaningful. The number of output codes therefore generally corresponds to the spreading factor 16.

Example:

The example shows the results of the poll for three active channels with the following configuration:

DPCH	1.16	(CC 4)	-7.0 dB
DPCH	2.8	(CC 3)	-7.3 dB
DPCH	3.4	(CC 2)	-8.0 dB

"INST:SEL BTDS"	'Activate TD-SCDMA BTS meaning 'CDP relative on screen A and 'Result Summary active on screen B
"INIT:CONT OFF"	'Select single sweep
"CALC2:FEED 'XTIM:CDEP'"	'Code domain error power evaluation
"INIT;*WAI"	'Start measurement with synchronization
"TRAC? TRACE1"	'Read out CDP relative

```

4, 1, -54.5, 1,
4, 2, -55.1, 0,
4, 3, -56.3, 1,
4, 4, -56.2, 1,
4, 5, -56.3, 0,
4, 6, -55.8, 0,
4, 7, -57.0, 0,
4, 8, -56.7, 0,
4, 9, -56.2, 1,
4, 10, -56.5, 1,
4, 11, -55.8, 1,
4, 12, -55.9, 1,
4, 13, -55.8, 0,
4, 14, -56.3, 0,
4, 15, -55.9, 0,
4, 16, -57.3, 0
    
```

CHANNEL TABLE (TRACE1)

The following is output for each channel:

Channel type	The channel type is coded by numbers as follows:
	0 = inactive
	1 = midamble
	2 = DPCH
	3 = P-CCPCH
	4 = S-CCPCH
	5 = FPACH
	6 = PDSCH
	7 = PICH

Code class	Code class of channel, values between 0 and 4
Code number	Code number of channel, values between 1 and 16

Modulation type	Modulation type of channel 0 = invalid (for midamble) 1 = QPSK 2 = 8PSK
Absolute level	In dBm
Relative level	In dB
Midamble shift	Values between 1 and 16
Δ MidD1	Power offset between sum power of channels (belonging to midamble(k), only data field 1) and midamble(k) Power
Δ MidD2	Power offset between sum power of channels (belonging to midamble(k), only data field 2) and midamble(k) Power
reserved 1	Reserved for additions
reserved 2	Reserved for additions

The class specifies the spreading factor of the channel

Class 4 is the highest spreading factor (16, data rate 17.6 kbps for QPSK, data rate 26.4 kbps for 8PSK), class 0 is the lowest spreading factor (1, data rate 281.6 kbps for QPSK, data rate 422.4 kbps for 8PSK).

Thus 11 values are transferred for all channels:

<Channel type>, <Code class>, <Code number>, <Modulation type>, <Absolute level in dBm>, <Relative level in dB>, <Midamble shift>, < Δ MidD1>, < Δ MidD2>, <Reserved 1>, <Reserved 2>

In code sorting (CONF:CDP:CTAB:ORD CODE), first all midambles are output, then the control channels, and finally the data channels in ascending order of code number.

In midamble sorting (CONF:CDP:CTAB:ORD MID), first the midamble is output and then its control and data channels.

Example:

The example shows the results of the poll for three channels in common midamble allocation with the following configuration:

```

Midamble m(3)          -3.0 dBm
DPCH  1.16             QPSK      -7.78 dBm
DPCH  2.8              QPSK      -7.78 dBm
DPCH  3.4              8PSK      -7.78 dBm

"INST:SEL BTDS"       'Activate TD-SCDMA BTS meaning
                      'CDP relative on screen A and
                      'Result Summary active on screen B

"INIT:CONT OFF"      'Select single sweep

"CALC2:FEED 'XTIM:CDP:ERR:CTAB'"
                      'Channel table evaluation

"INIT;*WAI"          'Start measurement with synchronization

"TRAC? TRACE1"       'Read out channel table
1, 0, 0, 0, -3.0, 0, 3, 0.005, 0.005, 0, 0
2 , 4, 1, 1, -7.78, -4.78, 3, 0, 0, 0, 0
2 , 3, 2, 1, -7.78, -4.78, 3, 0, 0, 0, 0
2 , 2, 3, 2, -7.78, -4.78, 3, 0, 0, 0, 0
0 , 4, 2, 1, -46.9, -43.9, 3, 0, 0, 0, 0
0 , 4, 5, 1, -46.9, -43.9, 3, 0, 0, 0, 0
0 , 4, 6, 1, -46.9, -43.9, 3, 0, 0, 0, 0
0 , 4, 7, 1, -46.9, -43.9, 3, 0, 0, 0, 0
0 , 4, 8, 1, -46.9, -43.9, 3, 0, 0, 0, 0
0 , 4, 13, 1, -46.9, -43.9, 3, 0, 0, 0, 0
0 , 4, 14, 1, -46.9, -43.9, 3, 0, 0, 0, 0
0 , 4, 15, 1, -46.9, -43.9, 3, 0, 0, 0, 0
0 , 4, 16, 1, -46.9, -43.9, 3, 0, 0, 0, 0

```

RESULT SUMMARY (TRACE2)

This command polls the measured and calculated values of code domain power analysis. The results are provided for the channel to which the code selected by the `CDPower:CODE` command belongs.

Parameters:

Global results of selected slot:

SLOT	Slot number		
PDATa	Power data fields in dBm	FERRor	Frequency error in Hz
PD1	Power data field 25.40 mm dBm	CERRor	Chip rate error in ppm
PD2	Power data field 2 in dBm	TFRame	Trigger to frame
PMIDamble	Power midamble in dBm	IQIMbalance	IQ imbalance in %
RHO	RHO	IQOFFset	IQ offset in %
MACCuracy	Composite EVM in %	ACTive	Number of active channels
PCDerror	Peak code domain error in dB		

Channel results:

SRATe	Data rate in kbps
CHANnel	Channel number
SFACTor	Spreading factor of channel
CDPRelative	Channel power relative in dB
CDPabsolute	Channel power absolute in dBm
EVMRms	Error vector magnitude RMS in %
EVMPeak	Error vector magnitude Peak in %

The results of *RESULT SUMMARY* are output in the following order:

<SLOT>, <PDATa>, <PD1>, <PD2>, <PMIDamble>, <RHO>, <MACCuracy>, <PCDerror>, <FERRor>, <CERRor>, <TFRame>, <IQIMbalance>, <IQOFFset>, <ACTive>, <SRATe>, <CHANnel>, <SFACTor>, <CDPRelative>, <CDPabsolute>, <EVMRms>, <EVMPeak>, <Reserved 1>, <Reserved 2>, <Reserved 3>, <Reserved 4>

The results have the following meanings and units:

Global results of selected slot:

SLOT	Slot number		
PDATa	Power data fields in dBm	FERRor	Frequency error in Hz
PD1	Power data field 1 in dBm	CERRor	Chip rate error in ppm
PD2	Power data field 2 in dBm	TFRame	Trigger to frame
PMIDamble	Power midamble in dBm	IQIMbalance	IQ imbalance in %
RHO	RHO	IQOFFset	IQ offset in %
MACCuracy	Composite EVM in %	ACTive	Number of active channels
PCDerror	Peak code domain error in dB		

Channel results:

SRATe	Data rate in kbps		
CHANnel	Channel number		
SFACTor	Spreading factor of channel		
CDPRelative	Channel power relative in dB	CDPabsolute	Channel power absolute in dBm
EVMRms	Error vector magnitude RMS in %		
EVMPeak	Error vector magnitude in %		

Note:

The trigger to frame (TFRame) value produces a "9" if the trigger is set to FREE RUN.

POWER VS SLOT ABS / REL (TRACE2)

The number of returned value tripels corresponds to the IQ capture length. (See `CDPower:IQLength` command, range 2 to 63.)

POWER VS SLOT ABS: <Slot number>,<Level in dBm>,<Validity>,<...>;

POWER VS SLOT REL: <Slot number>,<Level in dB>,<Validity>,<...>;

Validity is coded as follows:

- 0 = inactive (channel not occupied)
- 1 = active (channel occupied)
- 2 = alias (code class of channel < 4, i.e. several channels belong together)

PK CODE DOM ERR and COMPOSITE EVM (TRACE2)

The number of returned value pairs corresponds to the IQ capture length.
(See `CDPower: IQLength` command, range 2 to 63.)

PK CODE DOM ERR: <Slot number>, <Level in dB>,;
COMPOSITE EVM: <Slot number>, <Value in %>,;

SYMBOL EVM (TRACE2)

The number of values depends on the spreading factor:

Spreading factor 16:	44 values	Spreading factor 8:	88 values
Spreading factor 4:	176 values	Spreading factor 2:	352 values
Spreading factor 1:	704 values		

<Value in % symbol 0>, <Value in % symbol 1>,.....;

POWER VS SYMBOL (TRACE2)

The number of values depends on the spreading factor:

Spreading factor 16:	44 values	Spreading factor 8:	88 values
Spreading factor 4:	176 values	Spreading factor 2:	352 values
Spreading factor 1:	704 values		

<Value in dBm symbol 0>, <Value in dBm symbol 1>,.....;

SYMBOL CONST (TRACE2)

The number of value pairs depends on the spreading factor:

Spreading factor 16:	44 values	Spreading factor 8:	88 values
Spreading factor 4:	176 values	Spreading factor 2:	352 values
Spreading factor 1:	704 values		

Real and imaginary parts are transferred as value pairs.

<re 0>, <im 0>, <re 1>, <im 1>, <re n>, <im n>

COMPOSITE CONST (TRACe2):

The number of value pairs corresponds to the chip number of 704 data chips in a slot. Real and imaginary parts are transferred as value pairs:

<re chip 0>, <im chip 0>, <re chip 1>, <im chip 1>,.....;

BIT STREAM (TRACE2)

The bit stream of a channel is output. A value is output for each bit (range 0, 1), each symbol consists of two bits for QPSK channels and three bits for 8PSK channels.

The number of values depends on the spreading factor in QPSK:

Spreading factor 16:	88 values	Spreading factor 2:	704 values
Spreading factor 8:	176 values	Spreading factor 1:	1408 values
Spreading factor 4:	352 values		

In 8PSK:

Spreading factor 16:	132 values	Spreading factor 2:	1056 values
Spreading factor 8:	264 values	Spreading factor 1:	2112 values
Spreading factor 4:	528 values		

TRACe1:DATA? LIST

With this command the list evaluation results are queried in the following order:
 <no>, <start>, <stop>, <rbw>, <freq>, <power abs>, <power rel>, <delta>, <limit check>,
 <unused1>, <unused2>

All results are float values.

- no : range number
- start : start frequency
- stop : stop frequency
- rbw : resolution bandwidth of range
- freq : frequency of peak
- power abs : absolut power in dBm of peak
- power rel : relative power in dBc (related to the channel power) of peak
- delta : distance to the limit line in dB (positive indicates value above the limit, fail)
- limit check : limit fail (pass = 0, fail =1)
- unused1 : reserved (0.0)
- unused2 : reserved (0.0)

Example: "TRAC:DATA? LIST"

STATus:QUEStionable:SYNC register

This register contains information on the error situation in code domain power analysis of the FS-K76 option.

It can be polled with the commands "STATus:QUEStionable:SYNC:CONDition?" and "STATus:QUEStionable:SYNC[:EVENT]?".

Table 6-1 Meaning of bits in STATus:QUEStionable:SYNC register

Bit no.	Meaning
0	Not used in FS-K76 application
1	<p>K76 Frame sync failed</p> <p>This bit is set when synchronization is not possible within the application. The reasons for this can be:</p> <ul style="list-style-type: none"> Wrongly set frequency Wrongly set level Wrongly set scrambling code Wrongly set values for <i>INVERT Q</i> or <i>SIDEBAND INV</i> Invalid signal on input
2 to 14	Not used in the FS-K76 application.
15	This bit is always 0.

Table of softkeys with assignment of IEC/IEEE bus commands

MEAS key or MEAS hotkey

POWER	:CONFigure<1>:CDPower:MEASurement POWER Result poll: :CALCulate<1>:MARKer<1>:FUNction:POWER:RESult? CPower
ADAPT TO SIGNAL	
AUTO LEVEL&TIME	:[SENSe:]POWER:ACH:AUTO:LTIME
START SLOT	:[SENSe:]POWER:ACH:SLOT:START <num_value>
STOP SLOT	:[SENSe:]POWER:ACH:SLOT:STOP <num_value>
ACLR	:CONFigure<1>:CDPower:MEASurement ACLR Result poll :CALCulate<1>:MARKer<1>:FUNction:POWER:RESult? ACPower
NO: OF ADJ CHAN	:[SENSe:]POWER:ACH:ACP 2
ADJUST SETTINGS	:[SENSe:]POWER:ACH:PRES ACP CPower OBW
SWEEP TIME	:SWE:TIME 1 s
NOISE CORR ON OFF	:[SENSe:]POWER:NCORR ON
FAST ALCR ON OFF	:[SENSe:]POWER:HSP ON
DIAGRAM FULL SIZE	-
ADAPT TO SIGNAL	
AUTO LEVEL&TIME	:[SENSe:]POWER:ACH:AUTO:LTIME
START SLOT	:[SENSe:]POWER:ACH:SLOT:START <num_value>
STOP SLOT	:[SENSe:]POWER:ACH:SLOT:STOP <num_value>
ACLR LIMIT CHECK	:CALC:LIM:ACP ON :CALC:LIM:ACP:ACH:RES? :CALC:LIM:ACP:ALT:RES?

EDIT ACLR LIMIT	:CALC:LIM:ACP ON :CALC:LIM:ACP:ACH 0dB,0dB :CALC:LIM:ACP:ACH:STAT ON :CALC:LIM:ACP:ACH:ABS -10dBm,-10dBm :CALC:LIM:ACP:ACH:ABS:STAT ON :ALC:LIM:ACP:ALT1 0dB,0dB :CALC:LIM:ACP:ALT1:STAT ON :CALC:LIM:ACP:ALT1:ABS -10dBm,-10dBm :CALC:LIM:ACP:ALT1:ABS:STAT ON :CALC:LIM:ACP:ALT2 0dB,0dB :CALC:LIM:ACP:ALT2:STAT ON :CALC:LIM:ACP:ALT2:ABS -10dBm,-10dBm :CALC:LIM:ACP:ALT2:ABS:STAT ON
ADJ CHAN SPACING	:[SENSe:]POWer:ACH:SPAC:ACH 1.6MHz :[SENSe:]POWer:ACH:SPAC:ALT1 3.2MHz :[SENSe:]POWer:ACH:SPAC:ALT2 4.8MHz
ACLR ABS REL	:[SENSe:]POWer:ACH:MODE ABS
CHAN PWR / HZ	:CALC:MARK:FUNC:POWer:RES:PHZ ON OFF
POWER MODE	
CLEAR/ WRITE	:CALC:MARK:FUNC:POWer:MODE WRIT MAXH
MAX HOLD	
MULT CARR ACLR	:CONFigure:CDPower:MEASurement MCAClr Query of results: :CALCulate:MARKer:FUNction:POWerer:RESult? MCACpower
CP/ACP CONFIG	---
NO. OF TX CHAN	:[SENSe:]POWer:ACH:ACP 2
NO. OF ADJ CHAN	:[SENSe:]POWer:ACH:TXCH:COUN 4
CHANNEL BANDWIDTH	:POWer:ACH:BWID:CHAN <numeric_value> :POWer:ACH:BWID:ACH <numeric_value> :POWer:ACH:BWID:ALT1.<numeric_value>
CHANNEL SPACING	SENS:POWer:ACH:SPAC:CHAN <numeric_value> SENS:POWer:ACH:SPAC:ACH <numeric_value> SENS:POWer:ACH:SPAC:ALT1 <numeric_value> SENS:POWer:ACH:SPAC:ALT2 <numeric_value>
ACP REF SETTINGS	POWer:ACH:REF:TXCH:MAN1 POWer:ACH:REF:TXCH:AUTO MIN POWer:ACH:REF:TXCH:AUTO MAXPOWer:ACH:REF:TXCH:AUTO LHIG
CP/ACP ABS REL	POWer:ACH:MODE ABS
ADJUST SETTINGS	POWer:ACH:PRES MCAC
ACP LIMIT CHECK	:CALC:LIM:ACP ON :CALC:LIM:ACP:ACH:RES? :CALC:LIM:ACP:ALT1..11:RES?

EDIT ACP LIMIT	:CALC:LIM:ACP ON :CALC:LIM:ACP:ACH 0dB,0dB :CALC:LIM:ACP:ACH:STAT ON :CALC:LIM:ACP:ACH:ABS -10dBm,-10dBm :CALC:LIM:ACP:ACH:ABS:STAT ON :CALC:LIM:ACP:ALT1 0dB,0dB :CALC:LIM:ACP:ALT1:STAT ON
SWEEP TIME	SWE:TIM <Wert>
NOISE CORR ON OFF	: [SENSe:]POWer:NCOR ON
FAST ACP ONN OFF	: [SENSe:]POWer:HSP ON
FULL SIZE DIAGRAMM	:DISP:WIND1:SIZE LARG :DISP:WIND1:SIZE SMAL
POWERER MODE	:CALC:MARK:FUNC:POWer:MODE WRIT MAXH
ADAPT TO SIGNAL	: [SENSe:]POWer:ACH:AUTO:LTIME : [SENSe:]POWer:ACH:SLOT:START 1...7 : [SENSe:]POWer:ACH:SLOT:STOP 1...7 :CONFigure:CKPower:MEASurement ESpectrum
SPECTRUM EM MASK	Result poll: CALCulate<1>:LIMit<1>:FAIL? :CALCulate<1>:MARKer<1>:FUNction:POWerer:RESult? CPOWerer
LIMIT LINE AUTO	:CALC:LIM:ESP:MODE AUTO
LIMIT LINE MANUAL	:CALC:LIM:ESP:MODE MANual :CALCul:LIM:ESP:VAL <numeric_value>
LIMIT LINE USER	:CALC:LIMit<1>:NAME <string> :CALC:LIMit<1>:UNIT DBM :CALC:LIMit<1>:CONt[:DATA] <num_value>, <num_value>, ... :CALC:LIMit<1>:CONt:DOMain FREQuency :CALC:LIMit<1>:CONt:TRACe 1 :CALC:LIMit<1>:CONt:OFFset <num_value> :CALC:LIMit<1>:CONt:MODE RELative :CALC:LIM<1>:UPPer[:DATA] <num_value>, <num_value>.. :CALC:LIM<1>:UPPer:STATe ON OFF :CALC:LIM<1>:UPPer:OFFset <num_value> :CALC:LIM<1>:UPPer:MARGin <num_value> :CALC:LIM<1>:UPPer:MODE ABSolute :CALC:LIM<1>:UPPer:SPACing LINear
Notes:	
– If the Y values are entered with the command :CALCulate:LIMit<1>:LOWer[:DATA], the limit check is failed if the values are below the limit line.	
–If a user-defined limit line is enabled, this has priority over limit lines selected with AUTO or MANUAL.	
RESTORE STD LINES	:CALC:LIM:ESP:RESTore
ADAPT TO SIGNAL	
AUTO LEVEL&TIME	: [SENSe:]POWer:ACH:AUTO:LTIME

START SLOT	:[SENSe:]POWer:ACH:SLOT:START <num_value>
STOP SLOT	:[SENSe:]POWer:ACH:SLOT:STOP <num_value>
OCCUPIED BANDWIDTH	:CONFigure<1>:CDPower:MEASurement OBANdwidth Result poll: CALCulate<1>:MARKer<1>:FUNction:POWerer:RESult? OBANdwidth
% POWeRER BANDWIDTH	:[SENSe:]POWer:BWID 99PCT
ADJUST SETTINGS	:[SENSe:]POWer:PRES OBW
ADAPT TO SIGNAL	
AUTO LEVEL&TIME	:[SENSe:]POWer:ACH:AUTO:LTime
START SLOT	:[SENSe:]POWer:ACH:SLOT:START <num_value>
STOP SLOT	:[SENSe:]POWer:ACH:SLOT:STOP <num_value>
POWeRER VS TIME	:CONFigure:CDPower:MEASurement PVTime Result poll: CALCulate<1>:LIMit<1>:FAIL?
SWITCHING POINT	:CONFigure:CDPower:PVTime:SPOint <num_value>
RESTORE STD LINES	:CALC:LIM:PVTime:RESTore
NO OF SUBFRAMES	:CONFigure:CDPower:PVTime:SFRames <num_value>
AUTO LEVEL&TIME	:[SENSe:]POWer:ACH:AUTO:LTime
CODE DOM ANALYZER	:CONFigure:CDPower:MEASurement CDPower
SIGNAL STATISTIC	:CONFigure:CDPower:MEASurement CCDF oder :CALCulate:STATistics[:BTS]:CCDF[:STATe] ON Result Poll: CALCulate:MARKer:X?
APD	:CALC:STAT:APD ON
CCDF	:CALC:STAT:CCDF ON
PERCENT MARKER	:CALC:MARKr:Y:PERC 0...100%
NO OF SAMPLES	CALC:STAT:NSAM <value>
SCALING	
X-AXIS REF LVL	:CALC:STAT:SCAL:X:RLEV <value>

X-AXIS RANGE	:CALC:STAT:SCAL:X:RANG <value>
X-AXIS MAX VALUE	:CALC:STAT:SCAL:Y:UPP <value>
X-AXIS MIN VALUE	:CALC:STAT:SCAL:Y:LOW <value>
ADJUST SETTINGS	:CALC:STAT:SCAL:AUTO ONCE
DEFAULT SETTINGSL	:CALC:STAT:PRES
ADAPT TO SIGNAL	
AUTO LEVEL&TIME	: [SENSe:]POWer:ACH:AUTO:LTime Result poll: SENS:POWer:ACH:AUTO:LTIME?
START SLOT	: [SENSe:]POWer:ACH:SLOT:START <num_value>
STOP SLOT	: [SENSe:]POWer:ACH:SLOT:STOP <num_value>
CONT MEAS	: INIT:CONT ON; : INIT:IMM
SINGLE MEAS	: INIT:CONT OFF; : INIT:IMM

RESULTS hotkey or CODE DOM ANALYZER softkey

CODE DOM POWERER	:CALCulate<1>:FEED "XPOWER:CDP:RAT" (relative) :CALCulate<1>:FEED "XPOWER:CDP" (absolute)
CODE DOM ERROR	:CALCulate<1>:FEED "XPOWER:CDEP"
COMPOSITE EVM	:CALCulate<2>:FEED "XTIM:CDP:MACCuracy"
PK CODE DOM ERR	:CALCulate<2>:FEED "XTIM:CDP:ERR:PCDomain"
POWERER VS SLOT:	:CALCulate<2>:FEED "XTIM:CDP:PVSLOT:RAT" (relative) :CALCulate<2>:FEED "XTIM:CDP:PVSLOT:ABS" (absolute)
RESULT SUMMARY	:CALCulate<2>:FEED "XTIM:CDP:ERR:SUMM" Poll result: :CALCulate<1 2>:MARKer<1>:FUNctIon:CDPower[:BTS]:RESult? SLOT PDATa PD1 PD2 PMIDamble RHO MACCuracy PCDerror FERRor CERRor TFRame IQIMBalance IQOFFset ACTive SRATe CHANnel SFACTor CDPRelative CDPabsolute EVMRms EVMPeak
SELECT CHANNEL	:[SENSe:]CDPower:CODE 0..0.15
SELECT SLOT	:[SENSe:]CDPower:SLOT 0 ... (IQ_CAPTURE_LENGTH-1)
ADJUST REF LVL	:[SENSe:]POWER:ACH:PRES:RLEV
CHANNEL TABLE	:CALCulate<1>:FEED "XTIM:CDP:ERR:CTABLE"
CH TABLE CODE	:CONFigure:CDPower:CTABLE:ORDER CODE
CH TABLE MIDAMBLE	:CONFigure:CDPower:CTABLE:ORDER MIDamble
SYMBOL CONST	:CALCulate<2>:FEED "XTIM:CDP:SYMB:CONS"
SYMBOL EVM	:CALCulate<2>:FEED "XTIM:CDP:SYMB:EVM"
BIT STREAM	:CALCulate<2>:FEED "XTIM:CDP:BSTream"
COMPOSITE CONST	:CALCulate<2>:FEED "XTIM:CDP:COMP:CONS"
POWERER VS SYMBOL	:CALCulate<2>:FEED "XTIM:CDP:PVSY"
SELECT	
CAPTURE LENGTH	:[SENSe:]CDPower:IQLength 2..63
SET COUNT	:[SENSe:]CDPower:SET:COUNT 1..190 (nur R&S FSQ)

SET TO ANALYZE	: [SENSe:]CDPower:SET:[VALue] 0..(SET COUNT-1) (nur R&S FSQ)
SELECT CHANNEL	: [SENSe:]CDPower:CODE 0...16
SELECT SLOT	: [SENSe:]CDPower:SLOT 0 ... (IQ_CAPTURE_LENGTH-1)
SELECT CHANNEL	: [SENSe:]CDPower:CODE 1...16
SELECT SLOT	: [SENSe:]CDPower:SLOT 0 ... (IQ_CAPTURE_LENGTH-1)
ADJUST REF LVL	: [SENSe:]POWer:ACH:PRES:RLEV

CHAN CONF hotkey

CODE CHAN AUTOSEARCH	:CONFigure:CDPower[:BTS]:CTABLE[:STATE] OFF
CODE CHAN PREDEFINED	:CONFigure:CDPower[:BTS]:CTABLE[:STATE] ON :CONFigure:CDPower[:BTS]:CTABLE:SElect <channel table name>
EDIT CHAN CONF TABLE	---
NEW CHAN CONF TABLE	---
HEADER VALUES	CONFigure:CDPower[:BTS]:CTable:NAME "NEW_TAB" CONFigure:CDPower[:BTS]:CTable:DATA <numeric>,... CONFigure:CDPower[:BTS]:CTable:COMMENT "comment" CONFigure:CDPower[:BTS]:CTABLE:MSHift <numeric> CONFigure:CDPower[:BTS]:CTable:CATalog?
ADD SPECIAL	---
INSERT LINE	---
DELETE LINE	---
MEAS CHAN CONF TABLE	---
SAVE TABLE	---
SELECT SLOT	:[SENSe:]CDPower:SLOT 0 ... (IQ_CAPTURE_LENGTH-1)
SORT CODE	---
SORT MIDAMBLE	---
DEL CHAN CONF TABLE	:CONFigure:CDPower[:BTS]:CTABLE:DElete
COPY CHAN CONF TABLE	:CONFigure:CDPower[:BTS]:CTABLE:COPY "CTAB2"

SETTINGS hotkey

STANDARD 3GPP TSM	: [SENSe:]CDPower:STANdard GPP TSM
SCRAMBLING CODE	: [SENSe:]CDPower:SCODE 0..127
MA SHIFTS CELL	: [SENSe:]CDPower:MSHift 2 4 6 8 10 12 14 16
CAPTURE SETTINGS	
CAPTURE LENGTH	: [SENSe:]CDPower:IQLength 2..63
SET COUNT	: [SENSe:]CDPower:SET:COUNT 1..190 (nur R&S FSQ)
SET TO ANALYZE	: [SENSe:]CDPower:SET:[VALue] 0..(SET COUNT-1) (nur R&S FSQ)
SELECT CHANNEL	: [SENSe:]CDPower:CODE 0...16
SELECT SLOT	: [SENSe:]CDPower:SLOT 0 ... (IQ_CAPTURE_LENGTH-1)
INACT CHAN THRESHOLD	: [SENSe:]CDPower:ICTReshold -100 dB ... 0 dB
CODE PWR ABS REL	:CALCulate<1>:FEED "XPOWER:CDP:RAT" (relative) :CALCulate<1>:FEED "XPOWER:CDP" (absolute) :CALCulate<2>:FEED "XTIM:CDP:PVSL:RAT" (relative) :CALCulate<2>:FEED "XTIM:CDP:PVSL:ABS" (absolute)
INVERT Q ON OFF	: [SENSe]:CDP:QINVert ON OFF
SIDE BAND NORN INV	: [SENSe:]CDPower:SBAND NORMAl INVert
NORMALIZE ON OFF	: [SENSe:]CDPower:NORMAlize ON OFF
SYNC TO SLOT	: [SENSe:]CDPower:STSLOT ON OFF

7 Checking Rated Specifications

- Power off the analyzer before removing or inserting modules.
- Before powering the unit on, check the position of the line voltage selector (230 V).
- Measure the rated specifications after a warmup time of at least 30 min and completion of system error correction of the analyzer and the R&S SMIQ. This is the sole way of ensuring that rated specifications are maintained.
- Unless otherwise specified, all settings are made proceeding from the PRESET setting.
- The following conventions apply to settings on the analyzer during measurement:

[<KEY>] Press a key on the front panel, e.g. [FREQ].

[<SOFTKEY>] Press a softkey, e.g. [MARKER → PEAK].

[<nn unit>] Enter a value + terminate the entry with the unit, e.g. [12 kHz].

- The values in the following sections are not guaranteed. Only the specifications of the data sheet are binding.

Measuring equipment and accessories

Item	Instrument type	Recommended characteristics	Recommended equipment	R&S order no.	Uses
1	Signal generator	Vector signal generator	R&S SMIQ with options: SMIQB20 SMIQB11 SMIQB60 SMIQK14 SMIQ-Z5 PARADATA	1125.5555.xx 1125.5190.02 1085.4502.04 1136.4390.02 1105.1383.02 1104.8555.02	
2	Controller for generating signals with R&S WinIQSIM A PC that is either connected to the R&S SMIQ by a serial cable or has an IEC/IEEE bus card and is connected to the R&S SMIQ by an IEC/IEEE bus cable. Installed on this PC is the R&S WinIQSIM Software 4.00 or higher. This software can be downloaded from the Rohde & Schwarz Internet site .				

Test sequence

The performance test refers exclusively to results of the code domain analyzer.

There is no need to check the results of POWerER, ACLR and SPECTRUM measurements, since they are already covered by the performance test of the basic unit.

If you have not already done so, first generate the WinIQSIM file with the TD-SCDMA signal and transfer it to the R&S SMIQ under the name TDS_BS. This is explained in Chapter "Generating TD-SCDMA signal with R&S WinIQSIM" on page 10.

Default settings on
R&S SMIQ:

```
[PRESET]
[LEVEL:           0 dBm]
[FREQ:           2020.0 MHz]
ARB MOD
  SET SMIQ ACCORDING TO WAVEFORM ...
  SET SMIQ ACCORDING TO WAVEFORM ...   ON
  TRIGGER OUT MODE                       ON
```

(These settings are only needed once after presetting the generator and serve for automatically adopting the trigger setting from the waveform file generated by R&S WinIQSIM in ARB MOD. This is especially convenient when changing between different waveforms.)

```
SELECT WAVEFORM... Select name 'TDS_BS'
STATE:      ON
```

Default settings on
analyzer:

```
[PRESET]
[CENTER:         2020.0 MHz]
[AMPT:          10 dBm]
[TDS BS]
[TRIG           EXTERN]
[RESULTS       SELECT SLOT 4]
[RESULTS       CHANNEL TABLE]
```

Test setup and other
settings:

- Connect the RF output of the R&S SMIQ to the RF input of the analyzer.
- Connect the external trigger input of the analyzer to the TRIG1 port of the Z5 PARADATA BNC Adapter.
- Connect the external reference output of the analyzer to the R&S SMIQ.

```
R&S SMIQ  UTILITIES
           REF OSC
           SOURCE: EXT
```

```
Analyzer  [SETUP:           REFERENCE EXT]
```

The measurement result displayed on the screen of the analyzer should now be as follows:



BS,TDS:CHANNEL TAB

		CF 2 GHz		Chan	1.16					
				Slot	4					
	Type	Chan.SF	Data Rate kbps	Mod Type	Pwr.Abs dBm	Pwr.Rel dB	MA.shift	ΔMiD1 dB	ΔMiD2 dB	
Ref	Midamble	---	---	---	-1.17	0.00	8	0.00	0.00	A
9.00	DPCH	1.16	17.60	QPSK	-10.21	-9.04	8	---	---	
dBm	DPCH	2.16	17.60	QPSK	-10.19	-9.02	8	---	---	
Att	DPCH	3.16	17.60	QPSK	-10.20	-9.03	8	---	---	TRG
35 dB	DPCH	4.16	17.60	QPSK	-10.20	-9.03	8	---	---	
	DPCH	5.16	17.60	QPSK	-10.21	-9.04	8	---	---	
	DPCH	6.16	17.60	QPSK	-10.20	-9.03	8	---	---	
1	DPCH	7.16	17.60	QPSK	-10.20	-9.03	8	---	---	
CLRWR	DPCH	8.16	17.60	QPSK	-10.20	-9.02	8	---	---	
	---	9.16	---	---	-51.90	-50.73	--	---	---	

PRN

RESULT SUMMARY TABLE

DR 17.6 ksps

Chan 1.16

CF 2 GHz

Slot 4

		GLOBAL RESULTS			
Ref	Chip Rate Error	1.54 ppm	Trg to Frame	82 ns	B
9.00	SLOT RESULTS				
dBm	P Data	-1.17 dBm	Carr Freq Err	-2.72 kHz	
	P D1	-1.17 dBm	IQ Imbal/Offs	0.03/0.22 %	
Att	P D2	-1.17 dBm	RHO	0.9999	
35 dB	P Midamble	-1.17 dBm	Composite EVM	1.21 %	
	Active Channels	8	Pk CDE(SF 16)	-49.30 dB	
1	CHANNEL RESULTS				
CLRWR	Channel.SF	1.16	Data Rate	17.6 kbps	
	ChannelPwr Rel	-9.04 dB	ChannelPwr Abs	-10.21 dBm	
	Symbol EVM	0.72 %rms	Symbol EVM	1.27 %Pk	

8 Glossary

CDEP	Code domain error power
CDP	Code domain power
Composite EVM	According to 3GPP2 specifications, the square root of the squared error between the real and the imaginary parts of the test signal and an ideally generated reference signal is determined (EVM referred to the total signal) in composite EVM measurement
Crest factor	Ratio of peak to average value of the signal
Inactive channel threshold	Minimum power that a single channel must have compared with the total signal to be identified as an active channel
Midamble shift	Number for a segment of a basic midamble
P-CCPCH	Primary common control physical channel
RRC filter	Root raised cosine filter, for TD-SCDMA with rolloff of 0.22
S-CCPCH	Secondary common control physical channel
SF	Spreading factor
Slot	In TD-SCDMA, name for 864 chips or a time slot of 675 μ s
x.y	Channel number x.y, where: x is the code number, y is the spreading factor of the channel

9 Index

A

ACLR	30
Active Channels	64
Adjacent channel power	30
number of channels	31
Amplitude power distribution	51, 52
Amplitude probability distribution function	51, 52
Attenuation	
mechanical	83
Average	87

B

Bit stream	69
------------------	----

C

Carr Freq Err	64
CCDF	
complementary cumulative distribution function	51, 52
Center frequency	82
Chan.SF	66
Channel	
power	38
active	80
number	31
spacing	35
Channel number	75
Channel occupancy table	66
Channel power	28
absolute/relative	35
Channel Power Abs	64
Channel Power Rel	64
Channel SF	64
Channel type	75
Channel, active	131
Checking rated specifications	128
Chip Rate Error	64
Code domain error power	60
Code domain power	59
Commands	
assignment to softkey	119
assignment to softkeys	44
Complementary distribution function	52
Composite constellation	70
Composite EVM	64

D

Data rate	75
Data Rate	64, 66
Default setting	13
scaling on X-axis and Y-axis	54
Distribution function	52
Distribution function of signal amplitudes	51, 52

F

Fast power measurement	33
Frequency	
offset	82
Function fields	58

H

Hotkey	
CHAN CONF	24, 73
EXIT TDS	25
MEAS	25, 27
RESULTS	24, 57
SETTINGS	24, 78
TDS BS	24

I

IQ Imbal/Offs	64
---------------------	----

K

Key	
AMPT	83
BW	86
CAL	88
DISP	88
FILE	88
FREQ	82
HCOPY	89
LINES	88
MARKER	84
MEAS	27, 86
MKR FCTN	86
MKR →	85
PRESET	88
SETUP	89
SPAN	82
SWEEP	86
TRACE	87
TRIG	87

L

Limit	
ACP measurement	34
probability range	53
Limit check	
ACLR measurement	34

M

Ma Shift	66
Marker	
maximum	85
Max Hold	87

Maximum search	85	ADJUST SETTINGS.....	32, 48, 54
Menu overview.....	24	ADJUST SETTINGS (power measurements).....	38,
Midamble Shift.....	75	110
Min Hold	87	ALL MARKER OFF.....	84
Mod Type.....	66	APD ON/OFF.....	52
O		AUTO LEVEL & TIME ..	29, 34, 46, 48, 50, 54, 108
Offset		AVERAGE	87
frequency.....	82	BITSTREAM.....	57, 69, 113
Overwrite mode	87	CAPTURE LENGTH.....	60, 61, 62, 71, 79, 104
P		CAPTURE SETTINGS	79
P Data.....	64	CCDF ON/OFF.....	52, 99
P Midamble.....	64	CENTER.....	82
PD1/PD2.....	64	CF STEPSIZE	82
Peak code domain error	61	CH TABLE CODE.....	100
Peak value detection	87	CHAN PWR / HZ.....	35
Performance test	128	CHAN TABLE HEADER.....	97
Pk CDE.....	64	CHANNEL BANDWIDTH.....	37, 109
Power		CHANNEL SPACING	37, 112
ref. to 1 Hz bandwidth.....	35	CHANNEL TABLE.....	57, 66, 90, 100, 113
TD-SCDMA signal	40	CLEAR / WRITE.....	87
Power bandwidth		CODE CHAN AUTOSEARCH	73, 100
percentage.....	48	CODE CHAN PREDEFINED.....	73, 100
Power measurement		CODE DOM ANALYZER.....	27, 99
Fast.....	33	CODE DOM ERROR.....	57, 60, 90
Power versus symbol.....	70	CODE DOM POWER	57, 59, 90, 113
Preset.....	13	CODE PWR ABS / REL.....	80, 90
Pwr Abs/Pwr Rel.....	66	COMPOSITE CONST	70, 90
R		COMPOSITE EVM	57, 60, 90, 113
Rated specifications.....	128	CONT MEAS	54
RECENT.....	73	COPY CHAN CONF TABLE.....	77, 98
Reference level.....	83	CP/ACP ABS/REL	38, 109
Remote control	90	CP/ACP CONFIG	36
RF attenuation		DEFAULT SETTINGS	54
mechanical.....	83	DEL CHAN CONF TABLE.....	77, 99
RHO.....	64	DELETE LINE.....	76
S		DIAGRAM FULL SIZE	33
Scaling.....	53	EDIT ACLR LIMIT.....	34
Search		EDIT CHAN CONF TABLE.....	74, 99
maximum.....	85	FAST ACLR ON / OFF	33
Signal amplitudes, distribution function.....	51, 52	FREQUENCY OFFSET.....	82
Signal statistic.....	51, 52	HEADER / VALUES	75, 99
Slot	72, 80	HIGH DYNAMIC.....	50, 101
Softkey		INACT CHAN THRESHOLD	80, 103
% POWER BANDWIDTH	48	INSERT LINE	76
ACLR.....	27, 30, 99	INSTALL OPTION	8
ACLR ABS / REL	35	INVERT Q ON / OFF.....	81, 105
ACLR LIMIT CHECK	34, 36, 99	LIMIT LINE AUTO.....	41, 92
ACP REF SETTINGS	37, 110	LIMIT LINE MANUAL	41, 92
ADAPT TO SIGNAL.....	29, 34, 46, 48, 54	LIMIT LINE USER.....	44, 92
ADD SPECIAL	76, 98	LIST EVALUATION	45, 96
ADJ CHAN SPACING.....	35	MA SHIFTS CELL	79, 104
ADJUST REF LEVEL	83, 104	MARKER 1..4	84, 94
ADJUST REF LVL	72, 110	MARKER NORM/DELTA.....	84, 94
		MAX HOLD.....	87
		MEAS CHAN CONF TABLE.....	76
		MIN HOLD.....	87
		MULT CARR ACLR.....	36
		NEW CHAN CONF TABLE	77, 99
		NEXT MODE LEFT / RIGHT	85
		NEXT PEAK	85
		NO OF SAMPLES	52
		NO OF SUBFRAMES.....	50, 101
		NO. OF ADJ CHAN	31
		NO. OF TX CHAN	37, 112
		NOISE CORR ON / OFF.....	33, 112

NORMALIZE ON / OFF	81, 104
OCCUPIED BANDWIDTH	27, 47, 99
PEAK	85
PEAK MODE MIN / MAX	85
PERCENT MARKER	52
PK CODE DOM ERR	57, 61, 90, 113
POWER	27, 28, 99
POWER MODE	35, 39, 95
POWER VS SLOT	57, 62, 90, 113
POWER VS SYMBOL	57, 70, 90
POWER VS TIME	49, 99
REF LEVEL	83
REF VALUE POSITION	83
RESTORE STD LINES	44, 50
RESULT DISPLAY	90
RESULT SUMMARY	57, 64, 90, 113
RF ATTEN AUTO	83
RF ATTEN MANUAL	83
SAVE TABLE	76
SCALING	53
SCRAMBLING CODE	78, 105
SELECT	71
SELECT CHANNEL	71, 79, 103
SELECT MARKER	85
SELECT SLOT	72, 76, 80, 106
SET COUNT	71, 79, 105
SET TO ANALYZE	71, 79, 106
SIDEBAND NORM / INV	81, 105
SIGNAL STATISTIC	27, 51
SINGLE MEAS	54
SORT CODE	77
SORT MIDAMBLE	77
SPECTRUM EM MASK	27, 40, 99
STANDARD	41, 78, 106
START MEAS	50
START SLOT	29, 34, 46, 48, 54, 111
STOP SLOT	29, 34, 46, 48, 54
SWEEP COUNT	87
SWEEP TIME	33
SWITCHING POINT	50, 101
SYMBOL CONST	57, 68, 90, 113
SYMBOL EVM	57, 68, 90, 113
SYNC TO SLOT	81, 107
X-AXIS RANGE	53
X-AXIS REF LEVEL	53
Y PER DIV	83
Y-AXIS MAX VALUE	53
Y-AXIS MIN VALUE	53
Special channels	75
Spreading factor	75
Status	75
STATus	
QUEStionable	
SYNC register	118
Symbol constellation	68
Symbol error vector magnitude	68
Symbol EVM	64
Symbol rate	75

T

Test setup	22
Total power	35
Trace	
overwrite mode	87
peak value detection	87
Transducer	89
Trg to Frame	64

Δ

ΔMiD1	66
ΔMiD2	66